

Product data sheet

OndoSense *reach* D300

Distance radar sensor for harsh environments



ONDOSENSE
reach

Technical data

General data	
Measurement range ¹	0.30 - 40.00 m
Measurement rate	100 Hz
Linearity	up to ± 5 mm
Repeatability	up to ± 1 mm
Opening angle	$\pm 3^\circ$
Radar frequency (FMCW)	122.25 - 123 GHz
Radiation power	EIRP < 100 mW
MTTF	> 125 years

¹ Maximum range was established using a 0.35 m corner reflector

Mechanical data	
Width / Diameter	30 mm
Length	95 mm
Housing material	Stainless steel grade 1.4404
Lens material	PTFE
Connection	M12, 8-pin, a-coded connector
Weight	205 g (170 g sensor + 35 g M30 nuts)

Environmental data	
Protection class	IP67/IP69K
Operating temperature	-40 ... +70 °C
Storage temperature	-40 ... +85 °C

Electrical data	
Power supply	24.0 V DC (12 - 30 V)
Power dissipation	< 2.3 W

Electrical data

Pollution degree of the intended environment	Category IV
Max. altitude	2000 m (AMSL)
Reverse voltage protection	yes
Communication interface	RS485 (half-duplex mode)
Switching outputs	3x push-pull (PNP/NPN)
Analog outputs	Current loop (4 - 20 mA, single-ended, 12 Bit resolution)

Beam pattern

Typical beam pattern for a 0.35 m corner reflector.

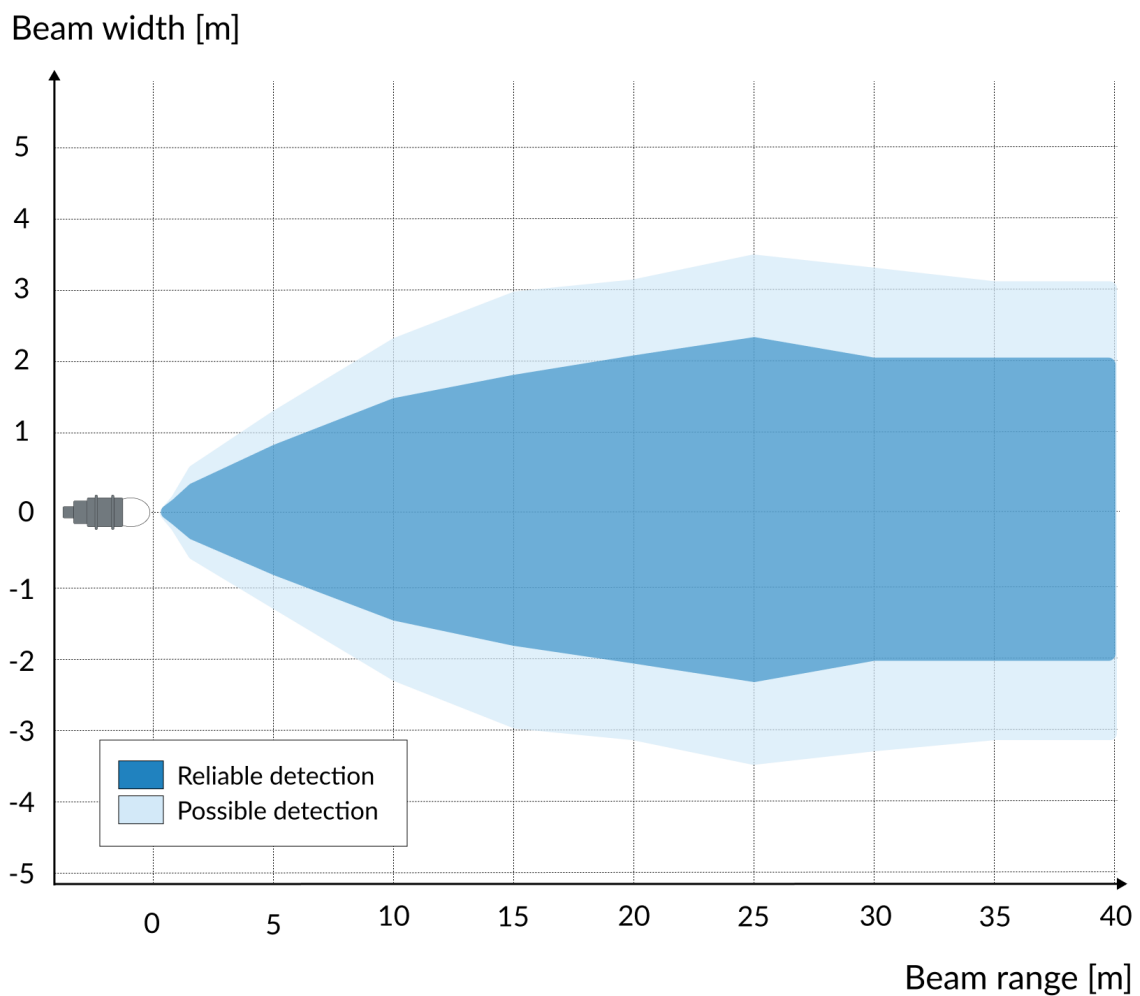

Note: The effective beam pattern depends on the sensitivity level, the target properties and the sensors measurement range.

Connection

V+ (24 V) and V- (GND) are used for the power supply. The pins A and B are used for RS485 data exchange. These 4 pins are needed for operating the sensor with RS485 communication. The sensor can be connected with an 8-pin a-coded M12 cable. Additional pins are the 3 switching outputs and the current loop.

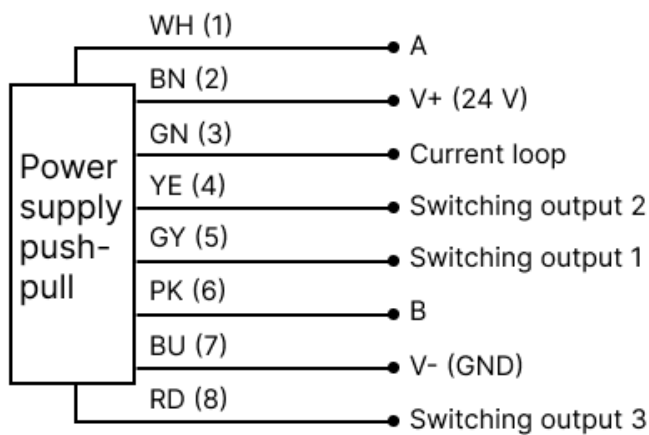

Pinout diagram sensor

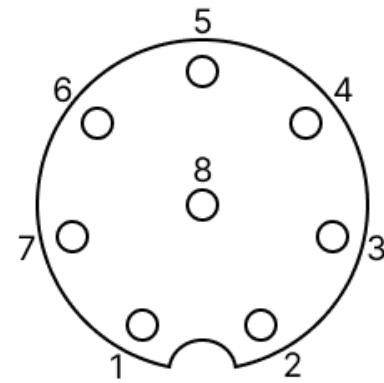

M12 8-pin a-coded male layout

Dimensional drawings

The lens geometry has been abstracted. All offered lenses will fit within the envelope.

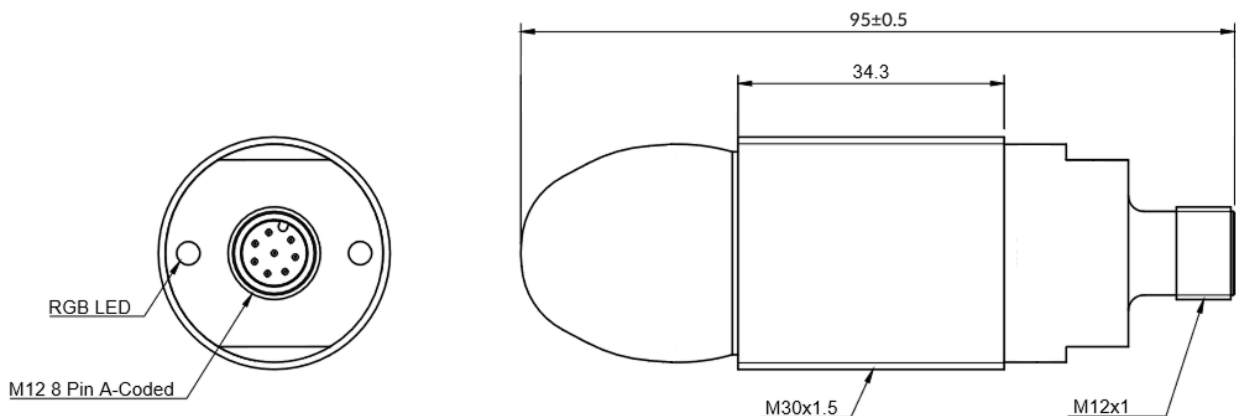

Accessories

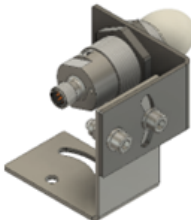
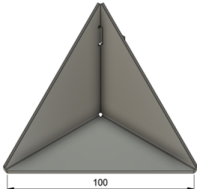
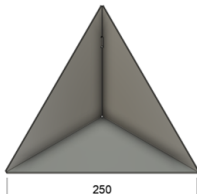
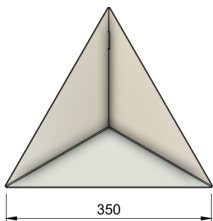
	Name	Description	Ordering Nr.
Install			
	M30 Mounting Bracket	Front-mounting of OndoSense reach with a horizontal range of $\pm 15^\circ$	MB.R100.1000
	M30 Swivel Bracket	Front-mounting of OndoSense reach with a horizontal and vertical range of $\pm 30^\circ$	MB.R200.1000
Reflect			
	CornerCube - 100	Increases the signal strength and the possible angle between sensor and target. RCS: 17 m ²	CC.0100.1000
	CornerCube - 250	Increases the signal strength and the possible angle between sensor and target. RCS: 677 m ²	CC.0250.1000
	CornerCube - 350	Increases the signal strength and the possible angle between sensor and target. RCS: 2602 m ²	CC.0350.1000