

Product data sheet

OndoSense apex D500

Radar distance sensor for harsh environments



Technical data

General data	
Radar frequency (FMCW)	122 - 123 GHz , 119 - 125 GHz (selectable)
Radiation power	EIRP < 100 mW
MTTF	> 105 years
Opening angle	± 1.5° (3°)
Measurement range	0.10 - 6.0 m
Measurement rate	500 Hz
Linearity for distances up to 2 m	±0.7 mm
Linearity for distances above 2 m	±0.035 % of MR
Repeatability for distances up to 2 m	±70 µm
Repeatability for distances above 2 m	±0.0035 % of MR

Mechanical data	
Dimensions (W x H x D)	120 mm x 86.5 mm x 88 mm
Housing material	Aluminum
Lens material	PTFE
Connection	M12, 4-pin d-coded female connector M12, 8-pin, a-coded male connector
Weight	800 g

Environmental data	
Protection class	IP67
Operating temperature	-40 ...+ 70 °C
Storage temperature	-40 ...+ 85 °C
EMC	EN 301 489-1 v2.2.3, EN 301 489-03 v2.3.2

Product data sheet

OndoSense apex D500



Electrical data	
Power supply	24 V DC \pm 15 % *
Power dissipation	< 4.5 W
Operation current	125 mA
Power dissipation	3 W
Reverse voltage protection	yes
Switching outputs	3x push-pull (PNP/NPN)
Analog output	Current loop (4 - 20 mA)

*Switching outputs (10 V - 40 V) and analog output (8 V - 40 V)

Profinet Data	
Communication interface	Profinet RT
Cycle time	1 ms
Data transfer	100 MBit/s
Line length	100 m
Classifications	<ul style="list-style-type: none">• RT Class 1• Conformance Class B• Netload Class III
Adjustable parameters	<ul style="list-style-type: none">• IP address• Device name• I&M 0...3 Parameter
Profinet characteristics	<ul style="list-style-type: none">• I&M 0...3• MRP• LLDP• PDEV• SNMP
Process data	<ul style="list-style-type: none">• Distance• Peak• Ramp Count• Sensor Temperature

Connection

M12 4-pin d-coded female Profinet connector: The pins Tx+ and Tx- are used for transmitting data, while Rx+ and Rx- are used for receiving data.

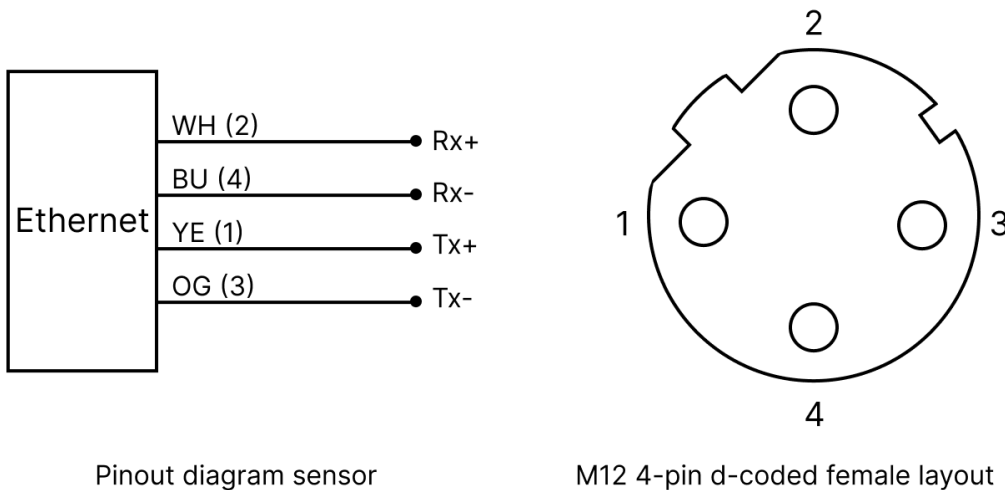

Pinout diagram sensor

M12 4-pin d-coded female layout

M12 8-pin a-coded male connector: V+ (24 V) and V- (GND) are used for the power supply. The pins A and B are used for RS485 connection to the ConfigBox. The sensor can be connected with an 8-pin a-coded M12 cable. Additional pins are the 3 switching outputs and the current loop.

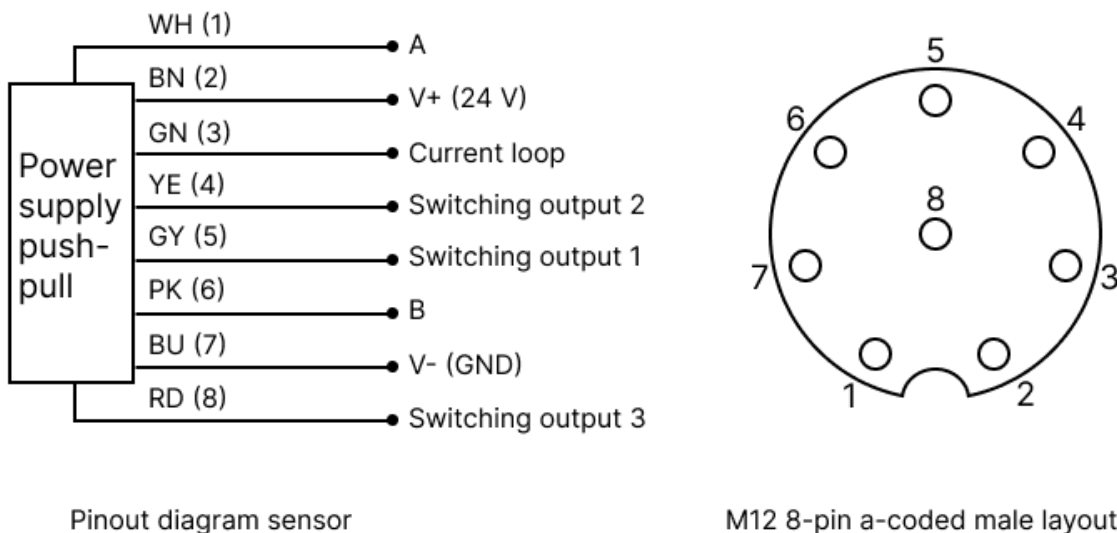

Pinout diagram sensor

M12 8-pin a-coded male layout

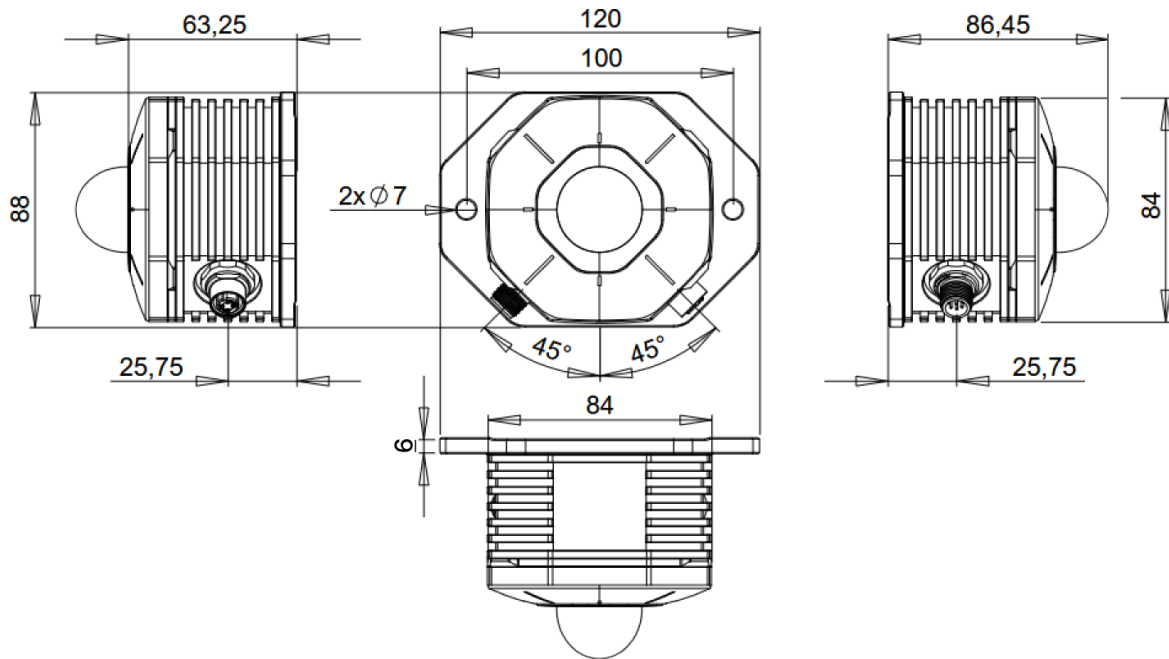

Dimensional drawings

The lens geometry has been abstracted. All offered lenses will fit within the envelope.



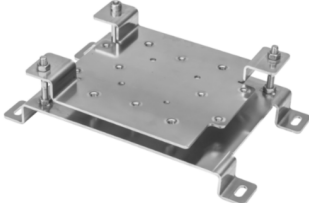

Accessories:

	Name	Description	Ordering
	OndoSense AngleControl	Precise alignment of OndoSense apex	MB.S200.1000
	OndoSense AirChill	Protection housing for OndoSense apex for high temperature environments.	PS.2200.1000