

# Product data sheet

## *apex* HP

Distance radar sensor for harsh environments



**ONDOSENSE**  
*apex*



## Technical Data

General data	
Radar frequency (FMCW)	119 - 125 GHz (selectable) 122 - 123 GHz
Radiation power	EIRP < 100 mW
MTTF	> 105 years
Opening angle	± 2°
Measurement range	0.30 - 8.00 m (calibrated range 0.1 - 1.4m)
Measurement rate	100 Hz
Measurement accuracy	< ± 700 µm (for calibrated range up to 1.4m)
Measurement precision	up to ± 1 µm (in High Precision Mode)

Mechanical data	
Dimensions (W x H x D)	80.0 mm x 79.2 mm x 75.0 mm
Housing material	Die-cast aluminum, painted
Lens material	PTFE
Connection	M12, 8-pin, a-coded male connector
Weight	415 g

Environmental data	
Protection class	IP67
Operating temperature	-40 ...+ 70°C
Storage temperature	-40 ...+ 85°C
EMC	IEC 61496-1, IEC 61000-6-2, IEC 61000-6-4

Electrical data	
Power supply	24.0 V DC (3.5 - 40 V) <sup>1</sup>
Power consumption	60 mA (at 24 V DC)
Power dissipation	1.44 W
Reverse voltage protection	yes
Communication interface	RS485 (half-duplex mode)
Switching outputs	3x push-pull (PNP/NPN)
Analog outputs	Current loop (4 - 20 mA)

<sup>1</sup>Switching outputs (10V - 40V) and Analog output (8V - 40V)

## Connection

V+ (24 V) and V- (GND) are used for the power supply. The pins A and B are used for RS485 data exchange. These 4 pins are needed for operating the sensor with RS485 communication. The sensor can be connected with an 8-pin a-coded M12 cable. Additional pins are the 3 switching outputs and the current loop.

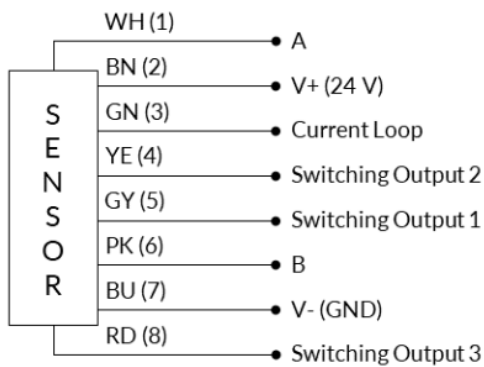

Pinout diagram sensor

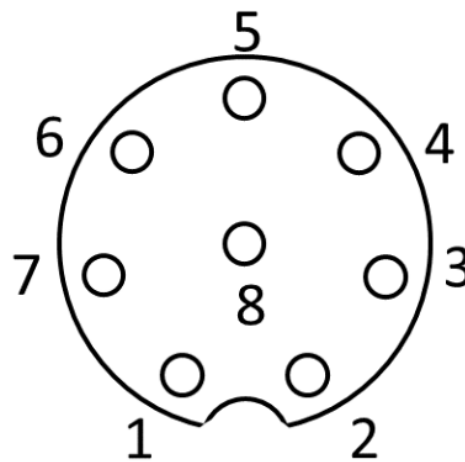

M12 a-coded male pin layout

### Dimensional Drawings

The lens geometry has been abstracted. All offered lenses will fit within the envelope.

