

# User Manual

## OndoSense *apex*

RS485 version



**ONDOSENSE**  
*apex*

## Table of Contents

<b>1</b>	<b>Important Safety Notes</b> .....	<b>5</b>
<b>2</b>	<b>General Information</b> .....	<b>6</b>
2.1	Legal Notices.....	6
2.2	Frequencies.....	6
2.3	Target Group.....	6
2.4	Preliminary Remark.....	6
2.5	Feedback.....	7
2.6	Used Symbols / Caution- and Security notes.....	7
2.7	Transport/Storage.....	7
2.8	Intended use.....	8
2.9	Improper use.....	8
2.10	Other Applicable Documents.....	8
<b>3</b>	<b>Radar Tutorial</b> .....	<b>10</b>
3.1	Distance Measurement with Radar.....	10
3.2	Radar penetrates non-conductive Materials.....	10
3.3	Opening Angle: Defining the Focus of the Radar Sensor.....	11
3.4	Radar Resolution and averaging across the Measuring Spot.....	12
<b>4</b>	<b>Product Information</b> .....	<b>14</b>
4.1	Technical Data.....	14
4.2	Productvariants.....	15
<b>5</b>	<b>Installation</b> .....	<b>16</b>
5.1	Sensor Setup.....	16
5.1.1	Physical Setup.....	16
5.1.2	Cable Setup.....	17
5.2	PLC Connection.....	18
5.2.1	Digital/Analog and Profinet Output.....	19



5.2.2	RS485 Connection.....	20
5.3	ConfigBox Connection.....	21
5.3.1	ConfigBox Connector.....	21
<b>6</b>	<b>Sensor Configuration .....</b>	<b>24</b>
6.1	Introduction to OndoNet.....	24
6.2	Standard Settings.....	29
6.2.1	Radar Signal set-up.....	29
6.2.2	Peak Selection .....	30
6.2.3	Measurement range.....	30
6.2.4	Adjust the Threshold .....	31
6.3	Advanced Settings .....	32
6.3.1	Filter and Smoothing.....	32
6.3.2	Distance Offset .....	34
6.3.3	Background Calibration .....	34
6.3.4	Threshold Sensitivity .....	35
6.3.5	Raw Data .....	36
6.4	Additional Options .....	38
6.4.1	Data Recording .....	38
6.4.2	Restart Measurement .....	39
6.4.3	Choose the radar profile .....	39
6.4.4	Fast Mode.....	40
6.5	Interfaces.....	40
6.5.1	Current Loop.....	40
6.5.2	Switching Outputs .....	40
6.6	High Precision Mode.....	41
6.6.1	Setup High Precision Mode.....	42
6.6.2	Target lost handling.....	43
6.6.3	Manual restart of the high precision mode.....	44
<b>7</b>	<b>System Management &amp; Maintenance.....</b>	<b>45</b>
7.1	IP-Adress Configuration.....	45
7.2	Save/Load Configuration .....	46
7.3	Update Software & Firmware .....	47



7.4 Maintenance .....48

8 Disposal.....49

9 Open Source Licenses .....50

10 Contact.....51



## 1 Important Safety Notes

 <b>CAUTION</b>	<p>Read this manual carefully before operating the sensor.</p> <p>Failure to follow these instructions may result in improper use or reduced performance. This manual provides essential information on the <b>use, maintenance, and safety</b> of the <b>OndoSense apex</b> radar sensor. For further assistance, please contact <a href="mailto:support@ondosense.com">support@ondosense.com</a>.</p>
--	---

## 2 General Information

### 2.1 Legal Notices

This work is protected by copyright. The associated rights are reserved by OndoSense GmbH. Reproduction of this document or parts of this document is only permissible within the limits of the legal provisions of copyright law. Any modification, abridgment, or translation of this document is prohibited without the express written permission of OndoSense GmbH. All rights reserved. Subject to errors and changes. The stated product features and technical data shall not constitute any guarantee declaration.

### 2.2 Frequencies

Our **OndoSense apex** radar sensors are technically suitable of using frequencies outside the ISM bands. In many countries, the usable bandwidth for production purposes is restricted to 1 GHz between 122 GHz and 123 GHz. Please check the local regulations. It is the customer's responsibility to ensure operation of the **OndoSense apex** radar sensors in accordance with local regulations. This applies in particular to broadband frequency uses outside of a laboratory environment. OndoSense assumes no liability for any consequences resulting from failure to comply with these instructions.

### 2.3 Target Group

The device may only be planned, mounted, commissioned and serviced by persons having the following qualifications and fulfilling the following conditions:

- Technical training.
- Briefing in the relevant safety guidelines.
- Constant access to this documentation.

 <b>CAUTION</b>	<p><b>Risk of injury due to insufficient training!</b> Improper handling may result in considerable personal injury and material damage. For this reason:</p> <ul style="list-style-type: none"><li>• All work must only ever be carried out by the stipulated persons.</li></ul>
--	---





### 2.4 Preliminary Remark

The following basic safety instructions are intended to avoid personal injuries and damage to property; they relate primarily to the use of the products described herein. If you additionally use further components, also consider their warnings and safety instructions.

## 2.5 Feedback

We endeavor to make these instructions as informative and clear as possible. If you have any suggestions or are missing information in the instructions, please send your feedback to: [support@ondosense.com](mailto:support@ondosense.com).

## 2.6 Used Symbols / Caution- and Security notes

 <b>DANGER</b>	<b>Classification:</b> This symbol, together with the signal word DANGER, warns against immediately imminent threat to life and health of persons. The non-compliance with this safety instruction will lead to death or severe adverse health effects.
 <b>WARNING</b>	<b>Classification:</b> This symbol, together with the signal word WARNING, warns against a potential danger to life and health of persons. The non-compliance with this safety instruction may lead to death or severe adverse health effects.
 <b>CAUTION</b>	<b>Classification:</b> This symbol, together with the signal word CAUTION, warns against a potential danger for the health of persons. The non-compliance with this safety instruction may lead to slight or minor adverse health effects.
<b>NOTICE</b>	<b>Classification:</b> The non-compliance with the Notice note may lead to material damage.
 <b>NOTE</b>	<b>Classification:</b> Additional information relating to the operation of the product, and hints and recommendations for efficient and trouble-free operation.

## 2.7 Transport/Storage

Check the delivery immediately upon receipt for possible transport damages. If you do not mount the device immediately, store it preferably in its transport package. The device must be stored at a dry location.

**NOTICE**

**Improperly transporting the distance sensor may damage it.**

Substantial material damage may result in the event of improper transport.

For this reason:

- The device should be transported only by trained specialist staff.
- The utmost care and attention is required at all times during unloading and transportation on company premises.
- Do not remove packaging until immediately before starting installation work.

## 2.8 Intended use

The **OndoSense apex** is a radar sensor for non-contact distance measurement of objects. OndoSense GmbH assumes no liability for losses or damage arising from the use of the product, either directly or indirectly. This applies in particular to uses of the product that do not conform to its intended purpose and are neither described nor mentioned in this documentation.

 **CAUTION**

**Sensor may become very hot during operation.**

Touching the sensor without caution may result in burns.

- Allow the sensor to cool before handling.
- If the sensor is too hot, use appropriate heat-resistant gloves.

## 2.9 Improper use

The **OndoSense apex** radar distance sensor is not intended as a safety component in accordance with the EC Machinery Directive (2006/42/EC). It must not be used in hazardous areas without proper explosion protection. Any other use that is not described as intended use is prohibited. Never install or connect accessories if their quantity and composition are not clearly specified, or if they have not been approved by OndoSense GmbH.

 **CAUTION**

**Danger due to improper use!**

Any improper use can result in dangerous situations. For this reason:

- Distance sensors should be used only according to intended use specifications.
- All information in these operating instructions must be strictly observed.

## 2.10 Other Applicable Documents

All technical data, as well as the mechanical and electrical characteristics, are specified in the data sheets of the corresponding device variant, for special versions in the corresponding quotation / customer drawing of the product.





All documents such as the original declarations of conformity or the relevant certificates can be downloaded from our support website.

**NOTICE**

For technical data and dimensional drawings, please refer to the data sheet of the respective product. We kindly ask you to save and retain all applicable documents at the time of commissioning.

### 3 Radar Tutorial

This chapter gives you a concise overview of radar technology, covering its key principles and practical applications. You'll gain an understanding of how radar sensors operate and the various factors that influence their performance

#### 3.1 Distance Measurement with Radar

Radar operates by emitting electromagnetic waves, which travel through the air at nearly the speed of light. When these waves encounter an object, they are reflected back towards the radar sensor. By analyzing the time delay and the frequency shift of the reflected waves, the radar sensor can accurately determine the distance and velocity of the object. This technology ensures precise and reliable measurements, making radar sensors essential for various applications.

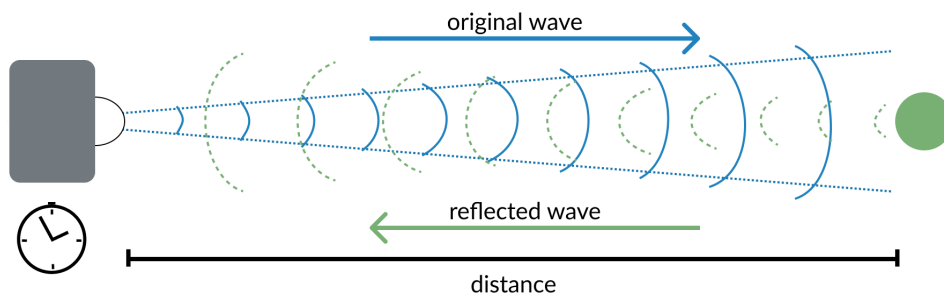

Distance measurement with electromagnetic waves

#### 3.2 Radar penetrates non-conductive Materials

Radar sensors can penetrate non-conductive materials such as plastic, rubber, cardboard, glass, and similar substances because radar waves are only partially reflected by these dielectric materials. Conversely, when radar waves encounter metals or closed water surfaces, they are fully reflected. This ability to penetrate certain substances or objects makes radar distance sensors highly versatile and suitable for a wide range of applications.

Material	Penetration	Description
Metal	✘	Impossible
Water/ water film	✘	Impossible in case of a closed water surface. Water drops can be penetrated.
Concrete	⚠	Difficult - depending on the thickness of the concrete
Wood	⚠	Low - the penetration decreases for an increased humidity content of the wood.

Material	Penetration	Description
Plastic / rubber	⚠️ - ✅	Medium to high - depending on thickness as well as plastic or rubber type
Paper / cardboard	✅	High - in case of low humidity content
Glass	✅	High - depending on the material's thickness.
Smoke / dust / steam	✅	High

Radar sensors can detect the distance to objects behind glass, plastic or other non-conducting materials. At the interface of the dielectric material, there is a weak reflection, which allows for the determination of the distance to the object. However, most of the radar waves radiate unhindered through this material, so that the distance to an object that is positioned behind the dielectric material can be determined. To protect the radar sensor from irradiation or explosions, glass, heat-resistant plastics or a mica plate can be used. Only a limited amount of the radar signal is reflected, so that the radar sensor detects the distance to the object behind it with high accuracy.

NOTE

**Radar allows you to measure through non-conductive materials:**  
While water drops and high humidity, dust and smoke do not have a big impact on the radar signal, closed water surfaces are more or less impossible to penetrate.

### 3.3 Opening Angle: Defining the Focus of the Radar Sensor

The measuring spot size of the radar distance sensor, influenced by the opening angle (or aperture angle), significantly affects target detection and interference reflections. Imagine the radar signal as a flashlight beam: a poorly focused flashlight illuminates a wide area but does not reach large distances, while a highly focused flashlight shines further and more precisely on specific objects.

Similarly, for radar sensors, a larger aperture angle results in a larger measuring spot, increasing the field of view but reducing measurement range and accuracy due to signal dispersion and interference. Conversely, a smaller opening angle provides a smaller, more focused measuring spot, enhancing signal strength and accuracy.

The figure below illustrates how the opening angle affects measuring spot size and signal strength. A smaller opening angle offers a stronger signal and higher accuracy.

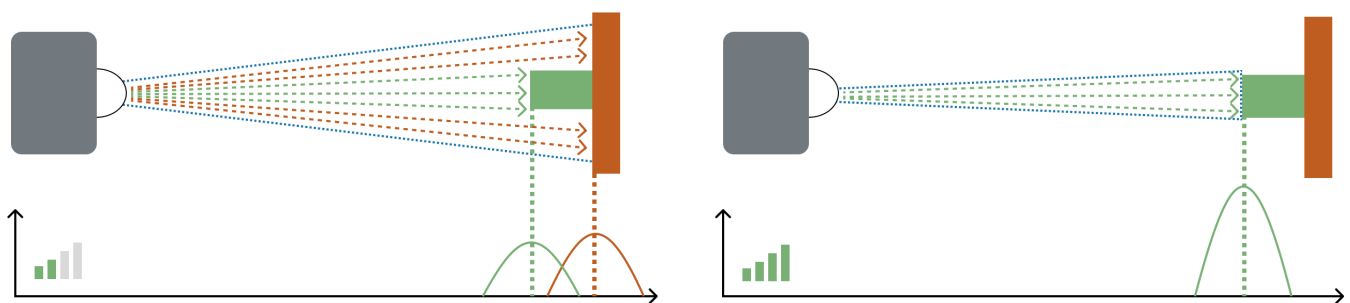

Opening angle affects measuring spot size

Use the [OndoSense radar spot size calculator](#) to determine your sensor's measuring spot size based on distance. Select your radar sensor from the list or input the opening angle and lens diameter for a calculation of the radar spot size in relation to a certain distance to the target object.

 <b>NOTE</b>	<p><b>Position the sensor closer:</b> Measure closer to the target to reduce the measuring spot size and minimize interference.</p> <p><b>Small opening angle = Increased Focus:</b> A small opening angle reduces interference reflections and improves measurement accuracy.</p> <p><b>Opening angle and detection orientation:</b> A smaller opening angle limits the maximum tilt the target object can have against the orientation of the sensor while still ensuring a stable signal output.</p>
---	---

### 3.4 Radar Resolution and averaging across the Measuring Spot

**Radar Resolution:** Radar resolution is critical for determining how well a radar distance sensor can distinguish between two closely spaced objects. It defines the minimum distance at which two objects can be separately detected. If the radar signals (peaks) from these objects can be distinguished, their distances can be accurately measured, as shown in the figure below.

**Averaging across the measuring spot:** When objects are positioned close together or surfaces have complex structures, and the distances between reflection points are smaller than the sensor's resolution, the sensor automatically averages the distance values. This ensures stable, consistent measurements, even on uneven or irregular surfaces. Stronger reflections are given more weight in the averaging process, leading to accurate and reliable readings. By smoothing out the impact of surface irregularities, averaging enhances the sensor's overall performance. For more advanced applications, OndoSense can create customized radar algorithms to further improve measurement precision.

If the radar signals (peaks) from these objects can be distinguished, their distances can be accurately measured. If the peaks from these objects or an uneven surface cannot be distinguished, the distance is averaged across the measuring spot as shown in the figure below.

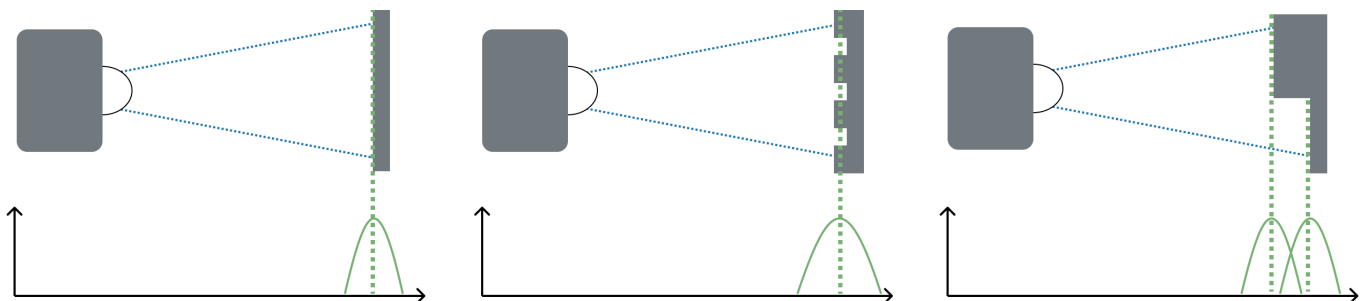

Averaging across measuring spot if the distance between reflection points is smaller than the resolution



**NOTE**

**Object Detection:**

Radar resolution enhances the sensor's ability to accurately detect and distinguish objects that are close to each other, ensuring reliable distance measurements for each individual object.

**Measurement Averaging:**

When multiple reflection points are within the sensor's resolution range, the sensor effectively averages the distances, providing a consistent measurement even in complex surface scenarios.

## 4 Product Information

This chapter provides comprehensive details about the technical data and all product variants.

### 4.1 Technical Data

<b>NOTICE</b>	All technical data, as well as the mechanical and electrical characteristics, are specified in the data sheets of the corresponding device variant.
---------------	---

<b>Mechanical data</b>	
<b>Dimensions (W x H x D)</b>	80.0 mm x 79.2 mm x 75.0 mm
<b>Housing material</b>	Die-cast aluminum, painted
<b>Lens material</b>	PTFE
<b>Connection</b>	M12, 8-pin, a-coded connector
<b>Weight</b>	415 g

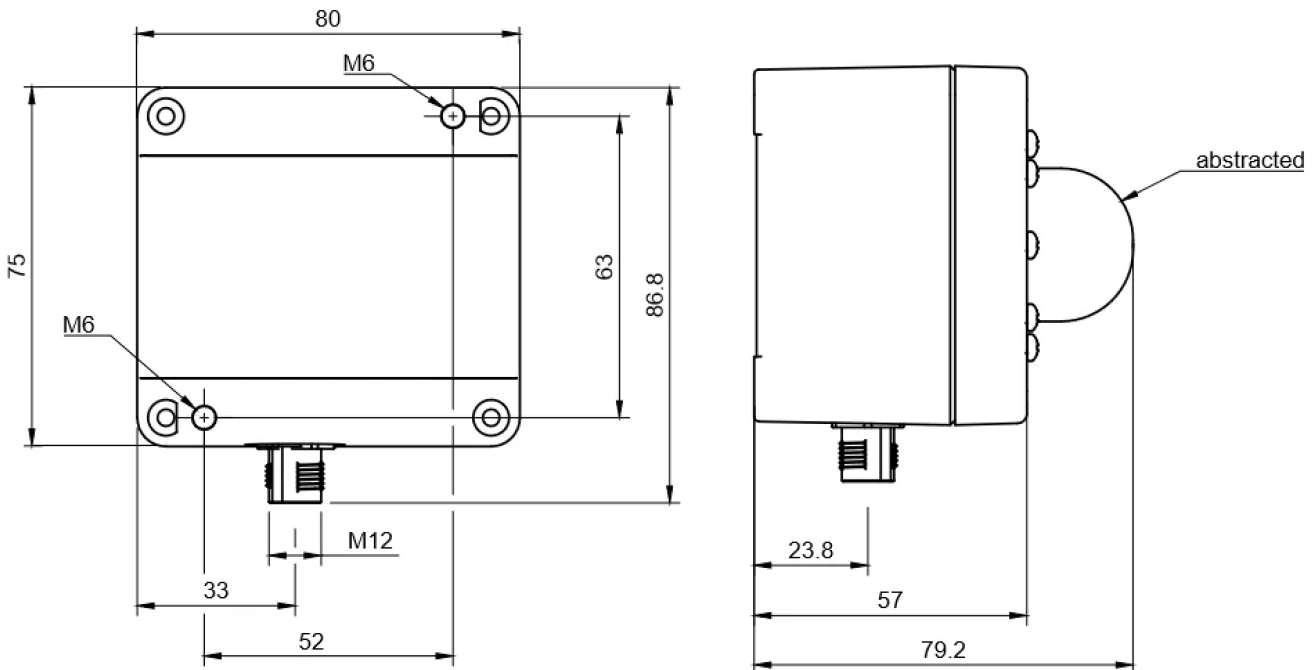

Device overview drawing

## 4.2 Productvariants

	Distance & Level	Precision
Measurement mode	Absolute distance	Displacement
Application examples	Dimension measurement, accurate level control, crane anti-collision	Profile measurement, accurate distance change, building monitoring
Measurement range	0.1 m - 6 m / 0.3 m - 40 m	0.1 m - 40 m
Linearity	up to $\pm 0.3$ mm	up to $\pm 1\mu\text{m}$ ( $\pm 0.1\%$ )
Repeatability	up to $\pm 0.1$ mm	up to $\pm 1\mu\text{m}$
Opening angle	$\pm 1.5^\circ$ ( $3^\circ$ )	$\pm 1.5^\circ$ ( $3^\circ$ )
Measurement rate	500 Hz	500 Hz

## 5 Installation

This chapter provides comprehensive details about the setup procedures, and electrical connection guidelines. You'll gain the essential knowledge needed to understand the product's capabilities and how to correctly install and operate it.

### 5.1 Sensor Setup

<b>NOTICE</b>	<b>Damage to the device due to transport or storage</b> Device failure, malfunction, device lifetime reduction. <ul style="list-style-type: none"><li>• Check the packaging and the device for possible damages.</li><li>• In the event of visible damages, do not use the device and do not put it into operation.</li><li>• Do not install the device after a fall or drop of the sensor.</li></ul>
<b>NOTICE</b>	<b>Do not disassemble or open the radar sensor</b> Sensors function may be lost partly or entirely <ul style="list-style-type: none"><li>• In no case disassemble the radar sensor entirely or partly.</li><li>• Do not modify the radar sensor.</li></ul>
<b>NOTICE</b>	<b>Do not expose the device to impact stress.</b> This would impair the sensors accuracy and reliability. <ul style="list-style-type: none"><li>• Do not use a hammer to align the radar sensor.</li><li>• Avoid impact stress.</li></ul>

#### 5.1.1 Physical Setup

Mount the sensor so that it is aimed perpendicular to the target.

Install the sensor at the optimal distance from the target as specified in the sensor's technical documentation. This ensures optimal performance and accurate measurements. Note that the further the distance, the larger the measuring spot. More information on this can be found in the [Radar Tutorial](#).

Use the appropriate mounting brackets and hardware to securely fix the sensor in place, ensuring it is stable and not prone to vibrations or movements. Ideally, the mounting bracket should allow for small adjustments to fine-tune the sensor's alignment.

Ensure that the sensor has a clear line of sight to the target with no obstructions. Make sure the bracket permits for a precise alignment of the sensor.



 <b>CAUTION</b>	<p><b>Ensure secure installation of the sensor.</b> An unsecured sensor may fall, causing injury or damage.</p> <ul style="list-style-type: none"><li>• Do not mount the sensor on unstable surfaces.</li><li>• Always use appropriate mounting hardware.</li></ul>
--	---

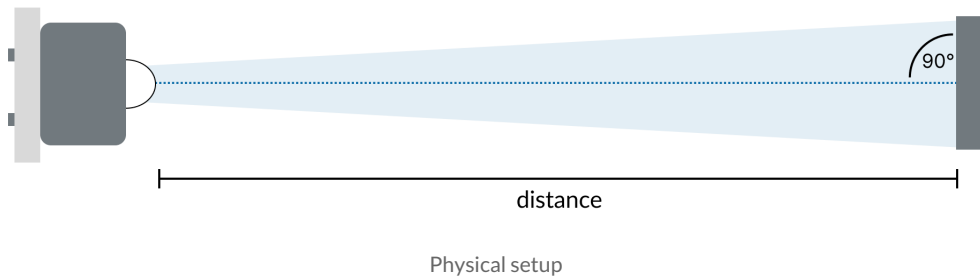

### 5.1.2 Cable Setup

For sensor connection, we offer three types of cables to suit different use cases:

1. **Female-Female Cable:** Designed for connecting the sensor to the ConfigBox.
2. **Female-Open End Cable:** Suitable for connecting the sensor directly to a PLC.
3. **Female-Male Cable:** Serves as an extension cable and can be used in both of the above cases.

There is a special use case for **RS485 communication** when using an adapter cable. For more details, please refer to [RS485 Connection](#).

## Cable use cases

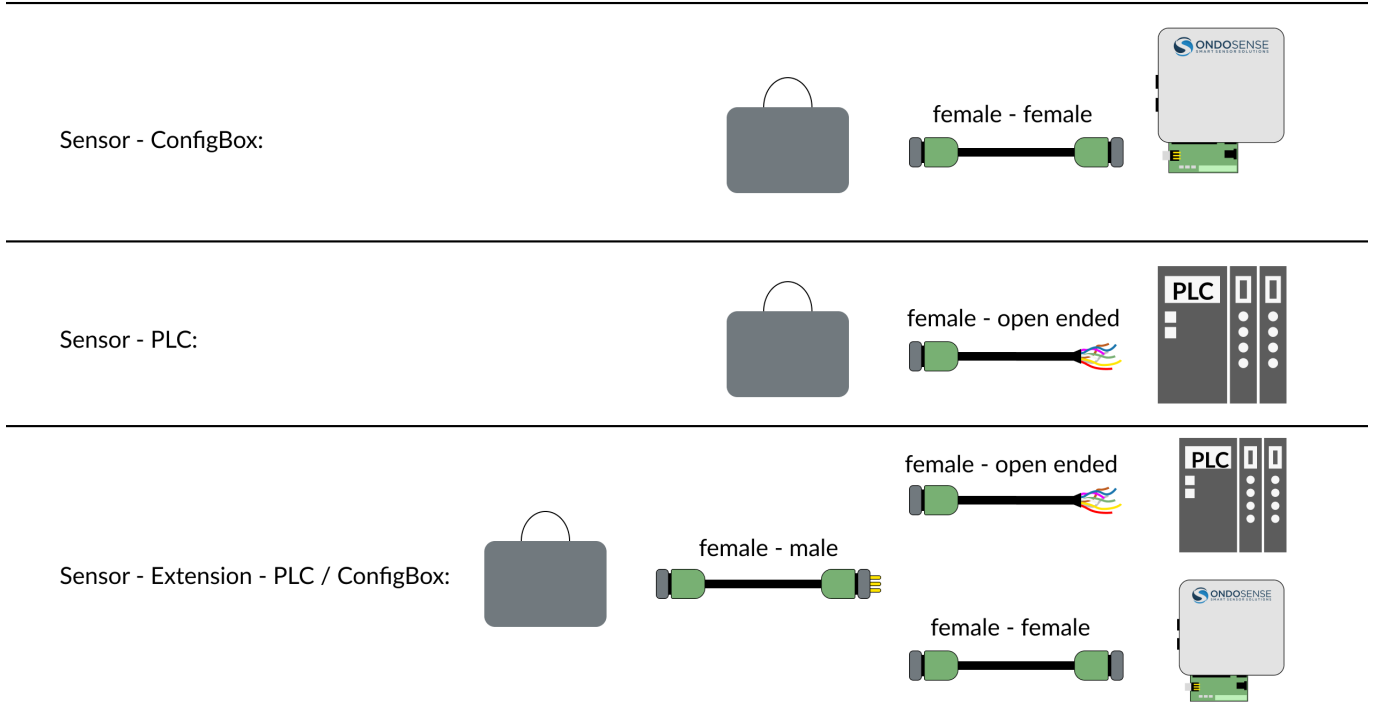

Cable use cases

## 5.2 PLC Connection

<b>NOTICE</b>	<p><b>Destruction of the device</b> Before connecting or disconnecting the signal cable, always disconnect the power supply and secure it against switching on again.</p>
<b>NOTICE</b>	<p><b>No open cable wires</b> Connect all required cable wires / connectors before commissioning. Insulate individually all unused ends of the output signals to avoid short-circuits. Electrostatic discharges at the contacts of the connector or at the line ends could damage or destroy the device. Take appropriate precautionary measures.</p>
<b>NOTICE</b>	<p><b>Traction relief</b> Always mount all lines with traction relief.</p>



## NOTE

To connect the sensor to your PLC, disconnect the **ConfigBox** from the sensor and connect an open ended M12 8-pin a-coded female cable. **Wait with this step until after you finished the sensor configuration.**

## 5.2.1 Digital/Analog and Profinet Output

Before connecting the sensor to your PLC, ensure that the sensor is precisely aligned and the switching outputs, analog output, and parameters are properly adjusted. The sensor is now ready to be connected to your PLC. You will need an open-ended M12 8-pin A-coded female cable for this connection. The color code below corresponds to the OndoSense cable. If you use a different cable, the color coding may vary.



## NOTE

The sensor can be disconnected from the ConfigBox and used as a stand-alone device. All parameters from the previous steps are automatically saved.

### Disconnect the Sensor from the ConfigBox:

- Disconnect the sensor from the ConfigBox. Ensure that the sensor remains aligned and all settings are saved. This will allow the sensor to function correctly once connected to the PLC.

### Connect the M12 8-pin A-coded Female Open-ended Cable:

- Attach the open-ended M12 8-pin A-coded female cable to the sensor. Make sure the connection is secure to avoid any communication issues between the sensor and the PLC.

### Power the Sensor:

- Connect the **brown** cable (V+ (24 V)) to the positive terminal of the power source.
- Connect the **blue** cable (V- (GND)) to the ground terminal of the power source.
- Ensuring proper power connections is crucial for the sensor to operate correctly.

### Digital Output - Switching Output:

- The **grey**, **yellow**, and **red** cables are responsible for transmitting the previously configured switching output signals:
  - **Grey Cable:** Connect to the appropriate input on the PLC for the first switching output.
  - **Yellow Cable:** Connect to the appropriate input on the PLC for the second switching output.
  - **Red Cable:** Connect to the appropriate input on the PLC for the third switching output.

### Analog Output - Current Loop:

- Connect the **green** cable to the appropriate input on the PLC to obtain the analog output. This will allow the PLC to read the analog signals sent by the sensor.

### Verify Connections and Power Up:

- Power up the system and ensure the sensor is receiving power.

- Verify that the PLC is correctly receiving the signals from the sensor.

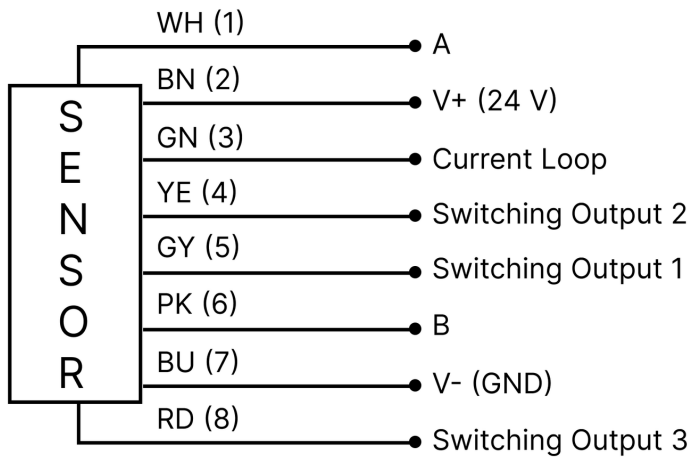

Pinout diagram sensor

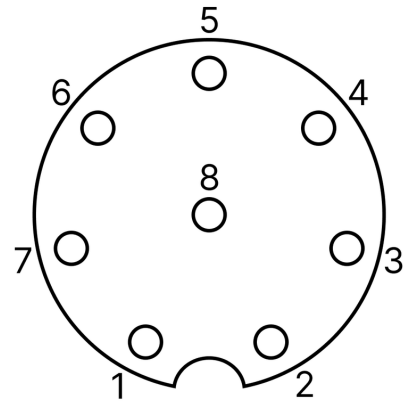

M12 8-pin a-coded male layout

Electrical connection

## 5.2.2 RS485 Connection

The **A** and **B** lines represent the RS485 communication interface of the sensor. For proper connection, follow these guidelines:

- **Using an M12 male open-end D-coded cable:**
  - Connect **A**, **B**, **GND**, and the **power cable (24 V)** to your PLC to ensure proper sensor operation.
- **Using an open ended USB/UART adapter:**
  - Connect **A**, **B**, and **GND** via the **screw terminal** on the ConfigBox connector circuit board (**ensure the ConfigBox is disconnected**).
  - For power supply, you can use either the **main power input** or the **screw terminal**. Ensure a stable **24 V supply**, as some adapter cables only provide **5 V**, which is insufficient.

### Important Notes:

- **No Parallel Use with OndoNet:** The RS485 lines (A and B) cannot be used while the ConfigBox is plugged into the sensor's signal connector. During this time, RS485 communication is disabled.
- **Restoring RS485 Communication:** After unplugging the ConfigBox from the circuit board, the A and B lines can be used again for RS485 communication.
- **Baud Rate Behavior:**
  - When connected to the ConfigBox, the sensor automatically operates at the **highest possible baud rate (921600 bps)**.

- This baud rate remains active **until the sensor undergoes a power cycle**.
- After a power cycle, the baud rate resets to the default value of **19200 bps**, while all other parameters configured via OndoNet remain intact.

To ensure reliable RS485 communication, confirm the proper wiring of **A**, **B**, and **GND**, and verify the baud rate after power cycles. For more details on RS485 communication, refer to the [Application Notes](#).

## 5.3 ConfigBox Connection

 <b>NOTE</b>	The ConfigBox is only required for the initial setup of the sensor for the specific application. Once the configuration is completed, the sensor can be disconnected from the ConfigBox and used as stand-alone device.
---	---

To connect the ConfigBox to your PC and start the configuration software OndoNet do the following:

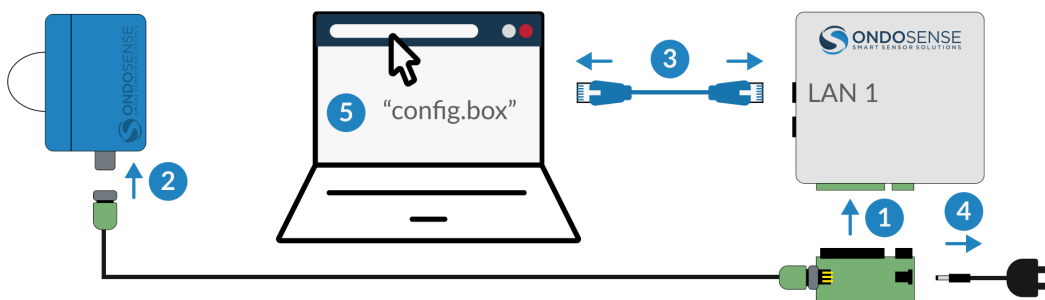

1. Connect the ConfigBox Connector to the ConfigBox
2. Use the female-female cable to connect the ConfigBox connector to the sensor.
3. Connect the ConfigBox on LAN-port 1 with a PC using an Ethernet cable.
4. Connect the power supply of the ConfigBox.
5. Open the browser on the PC and type in "config.box" into the address field to access OndoNet. This might take up to 1 minute. Make sure your computer's Ethernet settings are set to automatic DHCP.

You can now start with the configuration of the sensor as described in the chapter [Sensor Configuration](#) unless you want to include the ConfigBox into an existing network, which is described in the chapter [IP-Address Configuration](#).

### 5.3.1 ConfigBox Connector

 <b>NOTE</b>	The screw terminal for direct signal output allows parallel access to the sensor via OndoNet, while simultaneously reading the data from switching outputs and current loop into the PLC.
---	---

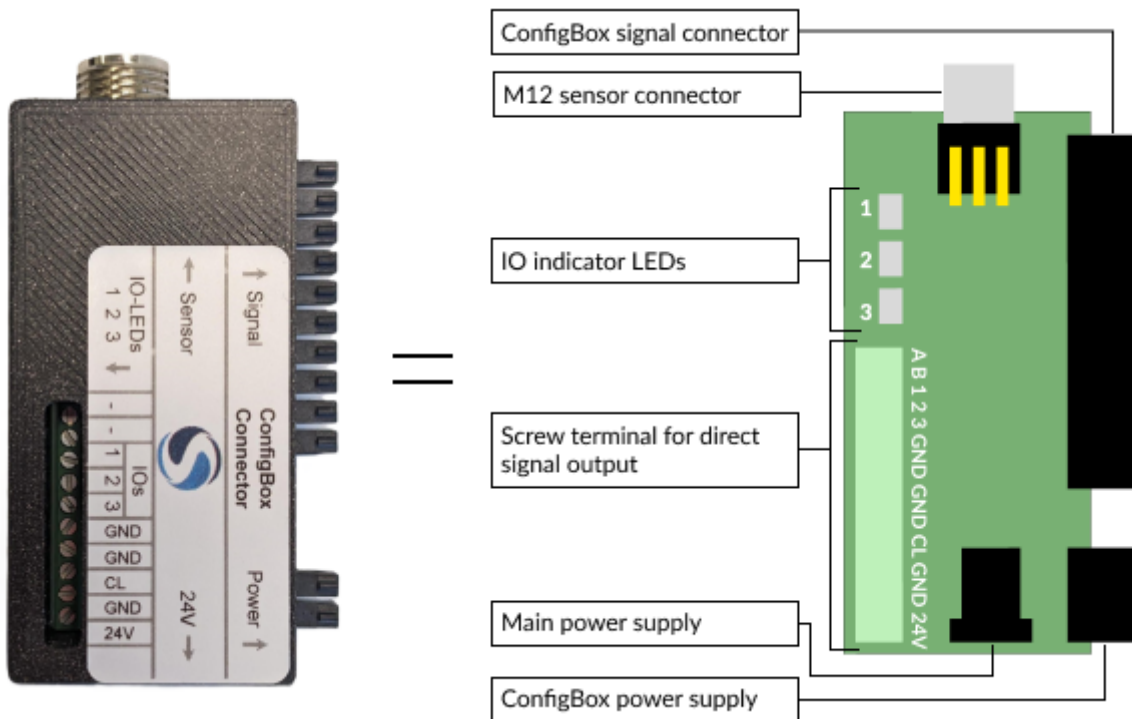

ConfigBox Connector

**ConfigBox signal connector:** Connect this to the ConfigBox.

**M12 sensor connector:** Use an M12 female-to-female cable to connect the circuit board to the sensor.

**IO Indicator LEDs:** Show the status of the three switching outputs.

**Main power supply:** Connect to a power source to power both the ConfigBox and sensor.

**ConfigBox power supply:** Supplies power to the ConfigBox.

**Screw terminal for direct signal output:**

If you need to read the data of the digital outputs and the current loop into the PLC, while access to the sensor via OndoNet you can use the screw terminal for direct signal output on the ConfigBoxConnect circuit board.

- GND (Ground) & 24V (Power supply):**  
Provided three times to simplify wiring. Connect GND to the PLC's GND terminal and connect 24V for power supply.
- A, B (RS485):**  
A and B are the RS485 lines. They must not be used parallel with OndoNet! Once the ConfigBox is plugged into the ConfigBox signal connector, RS485 via A and B cannot be used. After you unplug the ConfigBox from the circuit board, it is possible to use A and B again. Note: until the next power cycle, the baud rate will remain set to 921600 bps.
- 1, 2, 3 (Digital outputs):**  
These are the digital outputs 1, 2, and 3. Additionally, the IO indicator LEDs labeled 1, 2, 3 indicate the status of the switch outputs. "High" = LED is on, "Low" = LED is off.



- **CL ("Current loop"):** 4...20 mA output  
The CL output is connected to the analog input terminal of the PLC.

## 6 Sensor Configuration

This chapter guides you through the process of configuring your sensor, starting with an introduction to OndoNet. It covers the mandatory settings required for proper operation, explores advanced configuration options, and explains the digital and analog interfaces available for sensor output.

### 6.1 Introduction to OndoNet

After [connecting the ConfigBox to your sensor](#) and entering “config.box” in your browser’s address bar you will see the User Interface of OndoNet as displayed in the figure below.

 <b>NOTE</b>	If you experience slow performance enter “10.10.42.1” into the browser instead of “config.box”. In case the page does not load, make sure the LAN port of the PC is set to “DHCP” (i.e. automatically obtaining an IP address). To check this go to the Ethernet settings of your PC.
---	---



Interface of OndoNet

Description of the navigation tree on the left:

- **Home:** Returns you to the home page.
- **OS12345:** Expands to reveal the following menu options:
  - **Sensor Configuration:** The main page where you can view measured distances and modify parameters.
  - **IO Configuration:** Configure the switching and analog outputs here.
  - **Save/Load Configuration:** Save, load or reset your sensor configurations on this page.
- **Recorded Measurements:** Access your recorded distance measurements here, which were initially recorded on the Measurement Details page.





- **Sensor Management:** Find information about your sensor's version and type.
- **Tutorials & Documentation:** For additional information, click here to be redirected to the support website.
- **OndoNet Update:** Update the OndoNet software on your configuration page via this page.
- **Contact:** Find OndoSense's contact information here.

The **Details** button located below the sensor image redirects you to the Sensor Configuration page, and the **IO Config** button takes you to the IO Configuration page.

The numbers in the bottom left corner display the version of your OndoNet software.

After navigating to the **Sensor Configuration** page you should see OndoNet as displayed in the figure below.

**Target 2**

Chart Scale: Full Range | Details | Record | Switch Mode

Distance: 1763.1 mm | Mode: Standard

Distance [mm] vs Time [ms]

Filter: Max Distance [mm]: 2 | Max Time [ms]: 0 | Smoothing: Averaging Time [ms]: 0

**Settings 1**

Measurement Range: 100 - 100000 [mm]

Range [mm]: 100 - 9614 | Set

Distance Offset [mm]: 0

Adjust Signal Amplification: Auto Gain

Reset High Precision Mode Interval [ms]: 500 | Manual Reset

Radar Profile: Long Range - Fast moving objects

Fast Mode: Start

Restart Measurement: Restart Measurement

Background Calibration: Calibrate

View Mode: Standard | Advanced View

**Spectrum 3**

Magnitude | Add Hold | Threshold | Add Hold | Detected Peak(s) | Fix scale

Amplitude vs Distance [m]

Threshold: Threshold Sensitivity: 0 | Offset: 0 | Peak Selection: By Amplitude | Peak: 1

**Raw Data 4**

Channel | Add Hold | Channel | Add Hold | Fix scale

Amplitude vs Sample

Amplifiers: Pre Amp Gain: 2 | ADC Amp Gain: 147

4.13.0-RC1

Copyright © 2024 OndoSense GmbH. All rights reserved.

#RadarAccuracy

Sensor Configuration page of OndoNet



1. Settings Panel:		
Measurement Range	Standard	All signals received from outside the specified measuring range will be ignored.
Adjust Signal Amplification	Standard	Find the best amplifier parameter values.
Restart Measurement	Standard	Reinitializes all charts and reloads the page.
Radar Profile	Standard	Change the radar profile.
View Mode	Standard	Change from Standard to Advanced View.
Reset High Precision Mode Interval	Standard (only available for sensors with HP Mode)	Defines the time after which a measurement in High Precision Mode is reset, after it loses its target.
Background Calibration	Advanced	Takes a "snapshot" of the signals visible in the spectrum and subtracts these signals for all measurements done after the calibration, ensuring that only relevant signals are measured.
Distance Offset	Advanced	This value is added to the distance value.
Fast Mode	Advanced	Maximises the output rate of the distance values in the Target View by limiting the data that is being transmitted between sensor and ConfigBox.

2. Target View (displays the measured distance over time):		
Full Range	Standard	Displays the measured distance over time.
Details	Standard	The resolution of the y-axis is refined to enable you to view smaller variations of the distance in more detail.
Record	Standard	Enables to record distance value data and to export the data as CSV-file.
Switch Mode	Standard (only available for sensors with HP Mode)	Switches to High-Precision Mode.

2. Target View (displays the measured distance over time):		
Filter	Advanced	Filters sudden distance measurement jumps.
Smoothing	Advanced	Applies an exponential averaging.

3. Spectrum View (shows the signals received by the sensor over the measuring range. Note that the amplitude scale has arbitrary units):		
Magnitude/Add Hold	Standard	Hides or unhides the magnitude data/ Freezes or unfreezes the magnitude data.
Threshold (Offset)	Standard	Sets a constant signal amplitude threshold over the complete distance.
Peak Selection	Standard	Select the peak sorting method.
Fix scale	Standard	Fixes the scaling of the y-axis.
Threshold Sensitivity	Advanced	Suppresses undesired signals near the target signal.
Peak	Advanced	Select the peak you need for your measurement task.
Threshold/Add Hold	Advanced	Hides or unhides the threshold data/ Freezes or unfreezes the threshold data.
Detected Peak(s)	Advanced	Hides/Shows all the peaks that are detected in the spectrum.

4. Raw Data View (shows how the sampled time domain raw data):		
I Channel/Add Hold	Advanced	Hides or unhides the I channel data/ Freezes or unfreezes the I channel data.
Q Channel/Add Hold	Advanced	Hides or unhides the Q channel data/ Freezes or unfreezes the Q channel data.
Fix scale	Advanced	Fixes the scaling of the y-axis.
Amplifiers	Advanced	Click <b>AUTOGAIN</b> in the Settings panel for an automatic optimization.

## 6.2 Standard Settings

### 6.2.1 Radar Signal set-up

 <b>NOTE</b>	First, align the sensor perpendicular to the target. Then use the spectrum view for final adjustments. The smoother a surface, the more crucial the precise alignment of the radar sensor becomes.
---	--

The signal strength received by the radar sensor is one of the most important factors to achieve reliable measurement results. It is visualized by the amplitude of the spectrum in OndoNet. The signal strength increases when the sensor is aligned perpendicular to the target of the measurement.

Correctly aligning the sensor to the measurement target also avoids unintended reflections by other objects. This increases the signal strength and the Signal to Noise Ratio (SNR). Measurements with a high SNR are more robust to external interference.

Another factor that affects the signal strength of the measurement is the roughness of the surface. The rougher the surface, the higher the degree of tilting that allows for a stable radar signal. For smooth surfaces, the maximum possible tilting is lower than for rough surfaces. In contrast to measurements with for example laser sensors, rough surfaces are an advantage in measurements with radar sensors because the likelihood that a part of the beam is reflected back to the sensor is higher.

The figure below schematically shows the influence of the orientation of the sensor to the measurement target on the signal strength reflected back to the sensor. Perfectly perpendicular targets reflect a stronger signal to the sensor. With increasing tilting of the surface or object, the signal strength of the radar sensor decreases, as the radar radiation is increasingly not thrown back to the radar distance sensor.



Align sensor perpendicular to target for better signal strength

**Align the sensor towards the target:** Manually adjust the orientation of the sensor while monitoring the signal strength displayed in the configuration software. All detected objects and their signal strength are displayed in the “Spectrum” chart, which is positioned below the “Target” chart.

To monitor the signal strength while adjusting the sensor alignment, click on **FIX SCALE** and **ADD HOLD** for the magnitude in the spectrum chart. This way you can monitor whether your adjustment leads to an increase or a decrease of the signal strength. Continue until the optimal signal strength is reached.

If your target is too far away or the signal strength remains low, consider using a [radar reflector](#) to enhance the signal and improve detection accuracy.

**AutoGain:** Once you are done, click on **AUTO GAIN** in the “Settings” section to further optimize the signal strength. This will automatically adjust the gain parameters of the amplifiers.

If you have a changing distance to the target, please refer to the [Raw Data](#) chapter.

### 6.2.2 Peak Selection



#### NOTE

Select your peak by "Amplitude" if your target is characterized by the **strongest** signal. Choose "Distance" if your target is expected to be the **closest** peak.

With the Peak Selection feature, you can choose which peak you want to use in the measurement. The selected peak is indicated by the red line (a) in the spectrum view shown in the figure below. You can choose between the following options (g):

- Distance: Peak with the closest distance within the measurement distance (b)
- Amplitude: Peak with the highest amplitude (a)
- Normalized amplitude: Target with the highest Radar cross section.
- Distance backwards: Last peak by distance (d)
- Amplitude backwards: Last peak by amplitude (d)
- Normalized amplitude backwards: Target with the smallest Radar cross section.

### 6.2.3 Measurement range



#### NOTE

Limit the measurement range to the specific area of interest for your application.

The Measurement Range should be limited to the area of interest. It is the most effective way to avoid undesired interference signals from the surroundings. It can be changed in the Settings panel on the right (e). To save the changes use the set button. The values do not get saved automatically.

The first peak shown in the spectrum below is the self-reflection of the sensor (b). As it comes from the sensor itself and not from the target it should not be taken into account during the measurement. This can be avoided by adjusting the lower end of the measuring range to a higher value.

If you know the object you want to measure the distance to will always be located at a distance between 1m and 5 m, it is recommended to limit the measuring range to approximately 0.8m and 5.2 m. Any signals originating from objects at distances below the minimal distance or above the maximum distance will be ignored, leading to more robust measurement results in production.

## 6.2.4 Adjust the Threshold

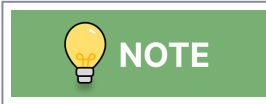

Setting a threshold can increase the robustness of the measurement, but can also lead to false negatives if set too high.

Setting a threshold is an effective way to improve the measurement robustness by suppressing targets with a lower signal strength than the signal of interest. This increases the robustness of the measurement significantly. The threshold (in amplitude) is indicated by the orange area in spectrum view (c) in the figure below and can be adjusted by changing the value in the Threshold field (f). Only peaks with a signal strength above this threshold (a) are considered, all others are suppressed (d).

To find the right threshold for your application first position the sensor perpendicular to the target such that the signal amplitude is maximised. Choose a target that is located at the maximal measurement distance. Then set the threshold approximately to 30% of the lowest signal strength. Monitor the measurement for a while to guarantee that the signal strength is never close to the threshold. In a case of doubt, it is always better to set the threshold lower. Be careful with using this feature for collision avoidance applications as a high threshold can lead to false negatives.



Peak selection, Measurement range and Threshold

## 6.3 Advanced Settings

### 6.3.1 Filter and Smoothing



#### NOTE

To ensure smooth and accurate measurements, applying filter or smoothing algorithms can be beneficial. To disable the filters, set the values to 0.

#### Filter

The filters help reduce sudden jumps in distance measurements, which can be caused by unwanted reflections not coming from the primary target. These jumps typically occur when the sensor's alignment to the main target is momentarily disrupted.

**Maximum Distance:** Set the maximum distance parameter to a value that represents the largest realistic difference between two consecutive measurements for your application. This ensures that only plausible changes in distance are accepted, while any distance differences exceeding this value will trigger the filter.

**Maximum Time:** Set the maximum time parameter to define the duration after which a new value should be accepted, even if an unrealistic distance jump occurred.

How the Filter Works:

- **Triggering the Filter:** The filter is activated when a sudden change between two consecutive measured distance values exceeds the defined maximum distance change.
- **Output During Filtering:** The sensor will continue to output the previous stable measurement until one of the following conditions is met:
  - **Restoring the Original Level:** The measured distance change returns to within the previous value  $\pm$  the maximum distance change. At this point, the sensor will start displaying the new measured value.
  - **Maximum Time Reached:** If the maximum time limit is reached before the original level is restored, the sensor will start displaying the new measured value.

By setting the parameters for maximum distance and maximum time, you ensure the sensor ignores erratic measurements and provides more stable and accurate readings.

The following figure is a simplified representation of the Target view, where x represents time and y represents the measured distance. The events a, b, and c illustrate jumps in the measurement values and how they are managed by the filter.

- a** The filter is not triggered because the change in distance between two consecutive values does not exceed the max distance parameter.
- b** The filter is triggered because the max distance is exceeded. The filter is then deactivated as the value returns to the original level.



**c** The filter is triggered because the max distance is exceeded. The filter is deactivated because the max time limit is reached, and the value is adjusted to the new measured distance.

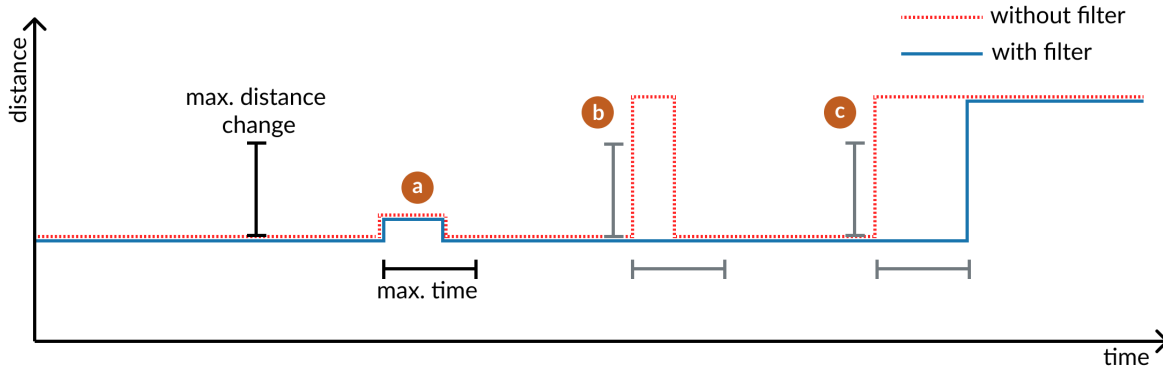

Filtered measurement events

## Smoothing

Smoothing applies exponential averaging to the measurements, which is useful for stabilizing fluctuating distances to the target. This is particularly helpful in dynamic applications, such as monitoring filling levels.

The averaging time affects the time frame over which the exponential averaging is applied and specifies that 95% of the output distance come from the new distance value.

The larger the averaging time, the slower the sensor adapts to new distance values, resulting in a more smoothed output. This means that sudden changes in distance are less immediately reflected in the measurements, providing a more stable reading at the expense of responsiveness. A shorter averaging time allows the sensor to respond more quickly to changes in distance, reflecting new values more rapidly but with less smoothing, which may result in a more fluctuating measurement.

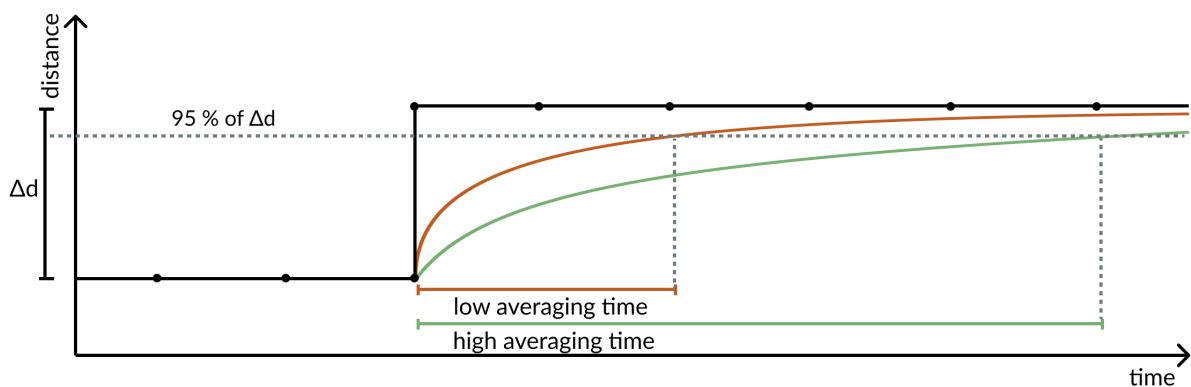

Smoothing algorithm

### 6.3.2 Distance Offset

 <b>NOTE</b>	The distance offset will be automatically added to all distance measurements, ensuring that the displayed distance values are accurate and reliable for your specific application.
---	--

The distance offset is a value that is added to the measured distance value to adjust for any systematic measurement errors or specific application requirements. By setting an appropriate distance offset, you can ensure that the sensor readings accurately reflect the actual distance to the target. This adjustment is particularly useful in scenarios where the sensor cannot be placed at the optimal measurement point or where inherent measurement biases need to be corrected.

To configure the distance offset, enter the desired value in the offset field. This value will be automatically added to all distance measurements, ensuring that the displayed distance values are accurate and reliable for your specific application.

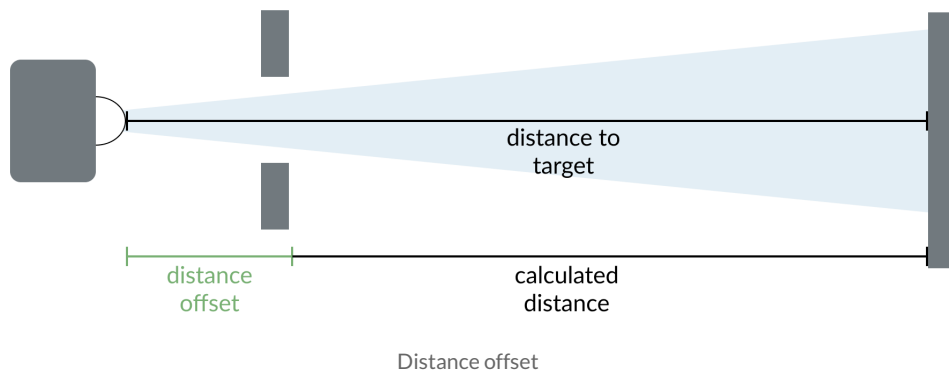

### 6.3.3 Background Calibration

 <b>NOTE</b>	The Background calibration is only useful for applications in which the surrounding is static and the sensor is not moved throughout the measurements
---	---

In some applications it may be useful to set a background calibration on the sensor. This is recommended, for example, if measurements are to be taken in a highly reflective environment and the reflections not required for the measurement are to be masked out.

The background calibration takes a "snapshot" of the signals visible in the spectrum and subtracts these signals for all measurements done after the calibration. Therefore, this setting is only useful for applications in which the surrounding is static and the sensor is not moved throughout the measurements.

To set the background calibration please do the following:

- 1. Measurements with the measurement object:**

Before you start setting the background calibration, position your measurement object at a medium distance within the measuring range. Please make sure that the sensor is positioned correctly, the measuring range and

the parameters in the raw data view are set appropriately. These cannot be easily changed after the background calibration is set. It must also be ensured that the sensor has been placed firmly, i.e. it should not be moved by vibrations or similar.

2. **Remove the measurement object:**

The goal of the background calibration is to subtract all signals originating from a static background in order to isolate the signals originating from the measurement object. Therefore, to take a "snapshot" of the background, please move the measurement object out of sight of the radar sensor.

3. **Setting the background calibration:**

After removing the measurement object, start setting the background calibration by clicking on the **CALIBRATE** button in the settings panel on the right and confirm it.

4. **Measurements with the measurement object:**

The background calibration is completed and you can now take measurements with the measurement object in sight of the sensor. The amount of signals visible in the spectrum view should be decreased compared to the amount of signals that were visible before the background calibration was set.

After successful calibration you will see a label "calibrated" above the individual views. Also, all amplifier settings in the raw data view are disabled. If you want to change these parameters, please remove the background calibration as described below, change the parameters and set the background calibration again.

After setting, it can take a few seconds until the sensor provides a good signal again. If your sensor is not firmly positioned and is moved, for example, by vibrations, you will be able to recognize this in the signal. The signal will then be very choppy and flicker.

Deleting the background calibration:

To delete the background calibration and thus reactivate the amplifier parameters in the raw data view, please click on the **REMOVE CALIBRATION** button in the settings panel on the right and confirm.

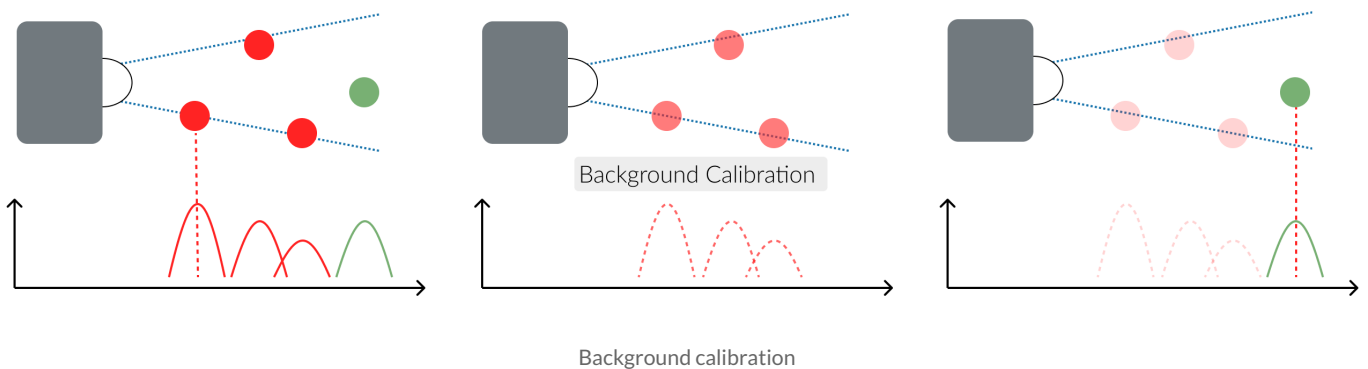

### 6.3.4 Threshold Sensitivity

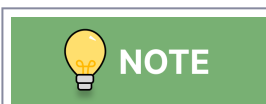

The Threshold Sensitivity suppresses undesired signals close to the target signal.

The Sensitivity feature is recommended for weak signals. It can improve the measurement robustness by suppressing undesired signals close to the target signal. The sensitivity calculation is based on an algorithm which identifies the main peaks of a spectrum and suppresses side peaks. The result of this calculation can be seen in the figure below,

where the threshold is low at the peak, but significantly higher next to the peak. The strength of this effect can be adjusted via the Sensitivity parameter.

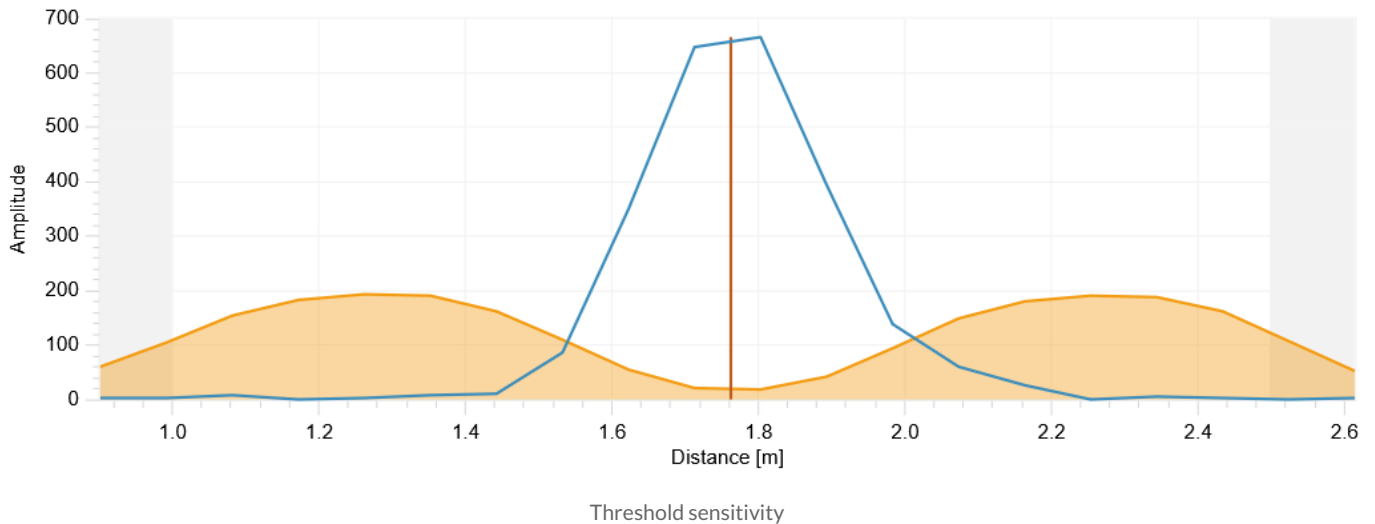

### 6.3.5 Raw Data



Use the **AUTO GAIN** button to optimize amplification parameters, significantly improving signal quality and measurement robustness.

The Raw Data view shows the echo raw data for the sampled time domain. It contains information about the distance and size of the target. The **AUTO GAIN** button automatically optimizes the amplification parameters for your specific application, significantly enhancing signal quality and measurement robustness. The suitable values of the amplification parameters differ between measurements. Therefore, they should be adjusted during a typical measurement.

If the target is in motion, it's recommended to click **AUTO GAIN** when the target is positioned midway between its maximum and minimum distances. If the furthest signal isn't detected with the initial amplification, move the sensor closer to the maximum distance and click **AUTO GAIN** again to recalibrate. If maintaining accuracy at close range is critical, configure **AUTO GAIN** at a closer distance, accepting that distant targets may not be reliably detected. Conversely, if distant targets are equally important, you might prioritize their detection and set **AUTO GAIN** at a further distance, even if it means accepting some clipping at closer ranges. Ultimately, the choice depends on which distance is more critical for your application.

The graph should show a sinus function with high amplitudes. The images below illustrate examples of both correct and incorrect settings. Optimal results are typically achieved when the curves range between -127 and +127, ensuring that the peaks of the curves are not clipped.

Even with clipped signals, the robust OndoSense algorithms can calculate the correct distance, although the measurement accuracy will be lower. If the signal received by the sensor is too weak for a meaningful measurement, a "weak signal" label will appear above this view.

If AutoGain, in combination with all other correctly set parameters, does not yield the desired results, you can manually adjust the ADC Amp Gain and Pre Amp Gain value incrementally while monitoring the raw data display. It is good practice to use the same amplifier values for I and Q, so the amplification parameters are linked. If you want to adjust the channels individually, click on the linked button.

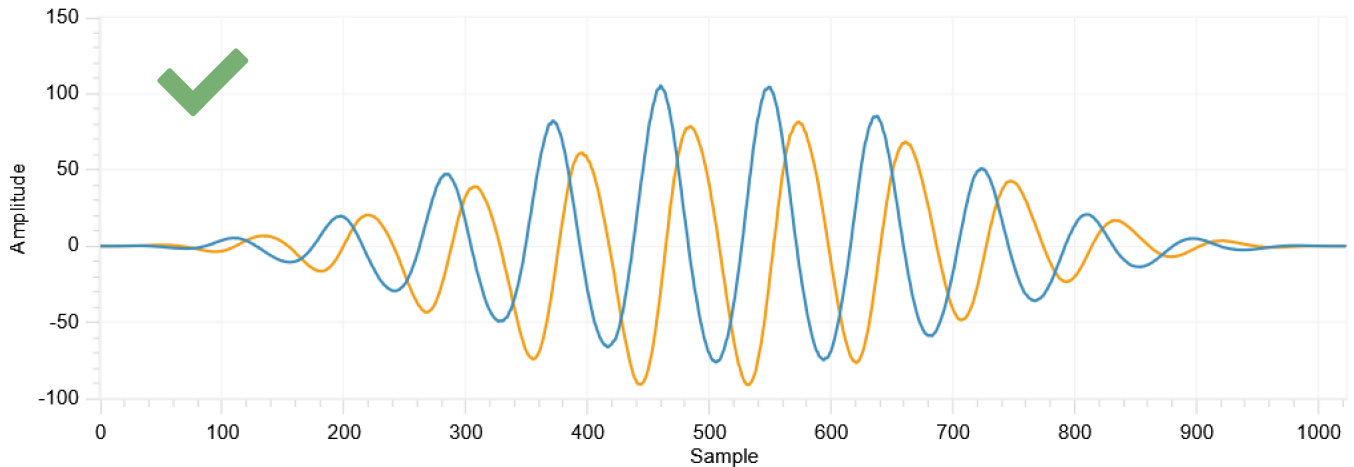

Ideal raw data signal

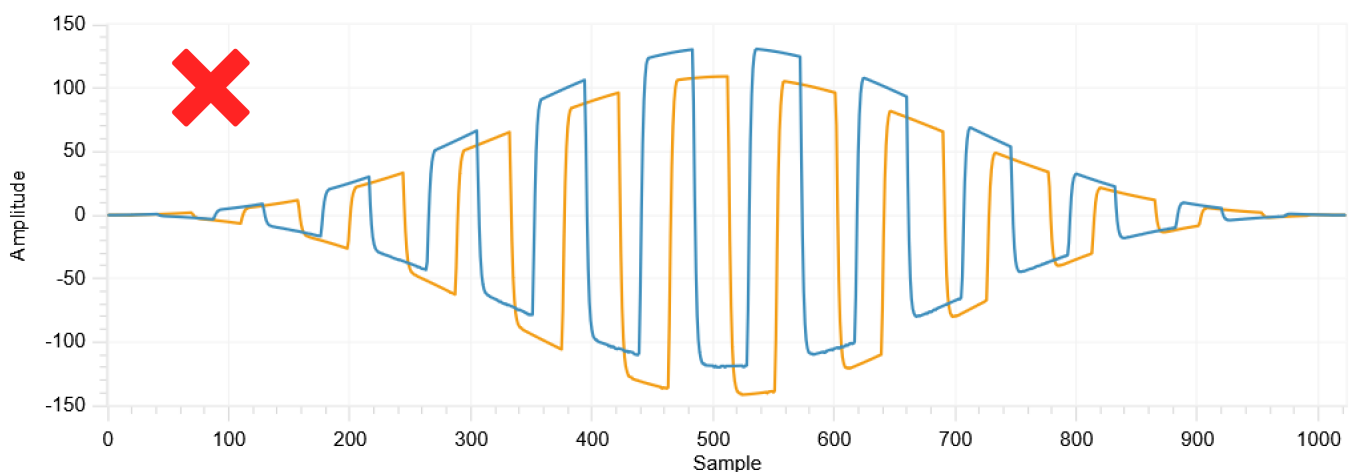

Extreme signal clipping

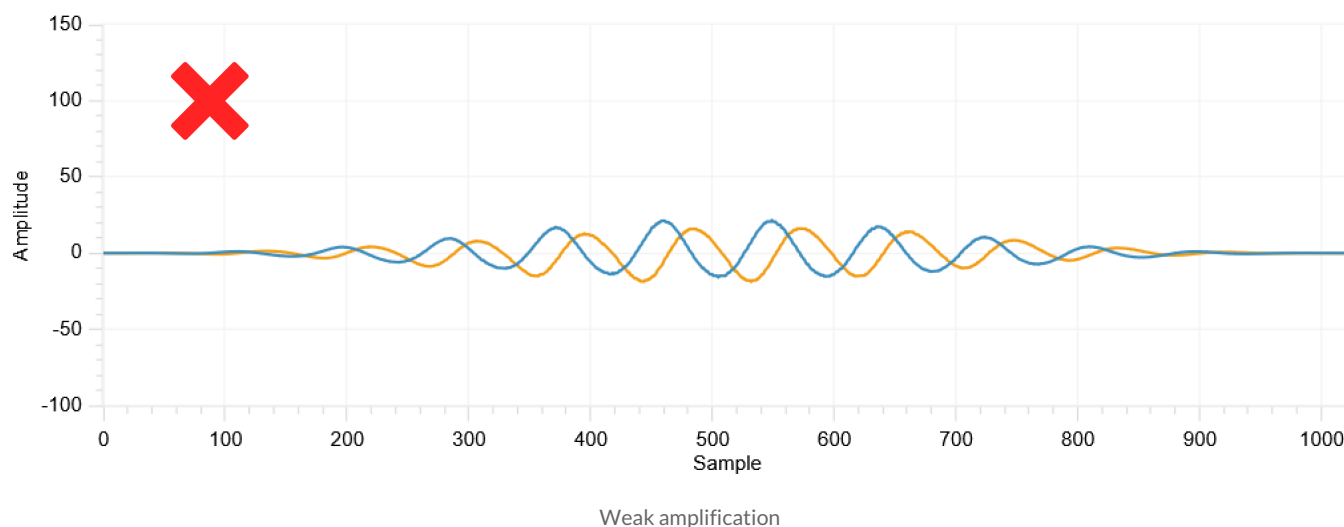

## 6.4 Additional Options

### 6.4.1 Data Recording



#### NOTE

The data recording function enables to record distance value data and to export the data as CSV-file.

To record data click on **RECORD** in top right corner of the target view. There you can enter a name for the measurement, specify the recording interval in seconds and click on Confirm. If you want to stop the recording, click the button, now named **STOP RECORDING** and confirm the end of the recording. During recording, a label is displayed above the view whose data is currently being recorded.

### Start Recording Distance Data ✕

<b>Name</b>	<b>Record Interval In Seconds</b>
<input type="text" value="Measurement #0"/>	<input type="text" value="0,5"/>

To see a list of all your recorded measurements please click on **RECORDED MEASUREMENTS** at the black navigation column on the left.

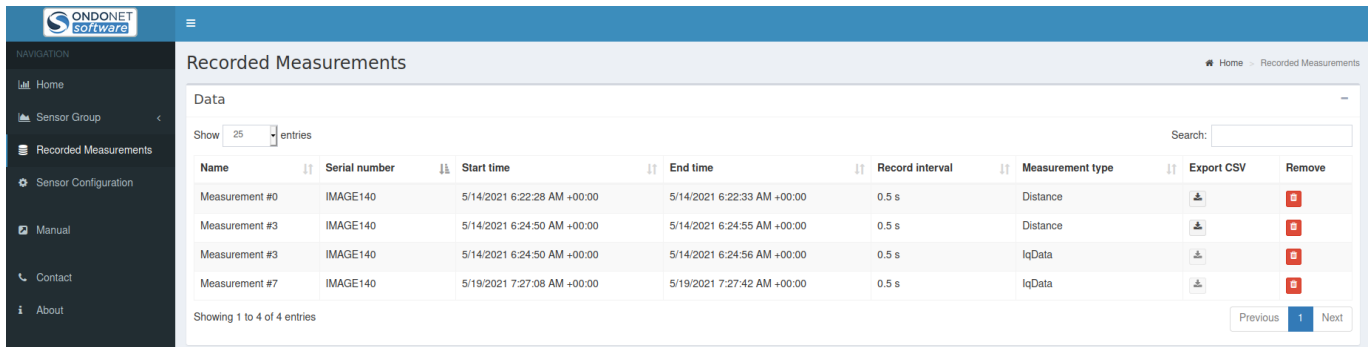

Name	Serial number	Start time	End time	Record interval	Measurement type	Export CSV	Remove
Measurement #0	IMAGE140	5/14/2021 6:22:28 AM +00:00	5/14/2021 6:22:33 AM +00:00	0.5 s	Distance		
Measurement #3	IMAGE140	5/14/2021 6:24:50 AM +00:00	5/14/2021 6:24:55 AM +00:00	0.5 s	Distance		
Measurement #3	IMAGE140	5/14/2021 6:24:50 AM +00:00	5/14/2021 6:24:56 AM +00:00	0.5 s	IqData		
Measurement #7	IMAGE140	5/19/2021 7:27:08 AM +00:00	5/19/2021 7:27:42 AM +00:00	0.5 s	IqData		

In the data list you can remove measurements from the list by clicking on the bin symbol in the Remove column. The measurements can be sorted differently by clicking the two arrows next to the column name. Measurements of type distance can be exported as a CSV file by clicking on the download symbol in the Export CSV column.

### 6.4.2 Restart Measurement

In the Settings section, the measurement can be restarted by clicking the **RESTART MEASUREMENT** button. This can be helpful in case there is no measurement data visible in the target and/or spectrum view.

### 6.4.3 Choose the radar profile

The sensors can operate within the 122-123 GHz frequency range, which is part of the ISM band and freely available for industrial use. Apart from this, it is possible to use the sensor in the 119 - 125 GHz frequency range. Utilizing this wider bandwidth enhances measurement accuracy. However, in this mode, it is crucial to ensure that the sensors do not cause interference. Compliance with local regulations governing this frequency range is mandatory.

Profil	Maximum Distance to CornerCube	Apex Variant
Long range, Fast moving objects	35 m	<b>Ondosense apex LR, Ondosense apex HP</b>
Close Range (up to 5m)	5 m	<b>Ondosense apex ST, Ondosense apex ST07, Ondosense apex DM, Ondosense apex HP</b>
Long Range, Slow moving objects	45 m	<b>Ondosense apex LR, Ondosense apex HP</b>
Maximum accuracy (up to 6m)	6 m	<b>Ondosense apex ST, Ondosense apex ST07, Ondosense apex DM, Ondosense apex HP</b>

### 6.4.4 Fast Mode

The **FAST MODE** button disables the data display in the Spectrum and Raw Data charts. This maximises the output rate of the distance values in the Target View, allowing for quicker real-time measurements.

## 6.5 Interfaces

### 6.5.1 Current Loop

**NOTE**

If no target is detected, the output defaults to 3.6 mA.

The Current Interface can be configured on the IO Configuration page, just below the settings for the switching outputs. Here, you can specify the distances in millimeters at which the current should be 4 mA and 20 mA, as illustrated in the figure below. The interface will output a current that corresponds to the distance of the target, with the current value linearly varying between the two defined distances.

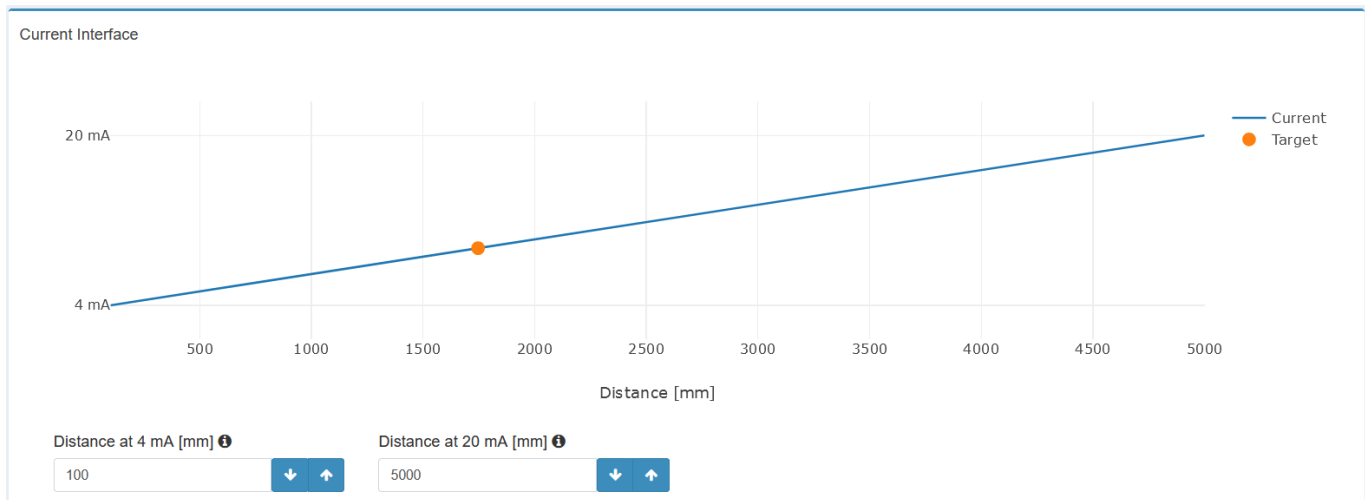

Interface for current loop

### 6.5.2 Switching Outputs

**NOTE**

If no target is detected, the output remains in its previous state.

Each of the switching outputs can be configured individually, as demonstrated for Output 1 in the figure below. Follow these steps to set up your desired output:

- **Distance to Active (Point 1):** Set the distance in millimeters at which the output should change to active.



- **Distance to Inactive (Point 2):** Set the distance in millimeters at which the output should revert to inactive (Window-Mode). For Single-Point mode, set this value to the maximum measuring range.
- **Hysteresis:** Define a window in millimeters to adjust the switching point based on the previous state. This helps prevent multiple switches if the target distance fluctuates around the switching point.
- **Mode:** Choose between "Active High" (PNP-mode) and "Active Low" (NPN-mode) to set the output mode.
  - **Active High (PNP-mode):** In this mode, the output is considered active when it sends a positive voltage (high state). This means that when the sensor detects the specified condition, it will switch to a high voltage state.
  - **Active Low (NPN-mode):** In this mode, the output is considered active when it sends a negative voltage or zero voltage (low state). This means that when the sensor detects the specified condition, it will switch to a low voltage state.
- **Delay:** Specify the time in milliseconds that the signal needs to be registered before switching to active.
- **Release:** Specify the time in milliseconds that the signal needs to be registered before switching to inactive.



Interface for switching output configuration

## 6.6 High Precision Mode



### NOTE

This Mode is only available for the **OndoSense apex HP** sensor

The High Precision Mode allows for the measurement of distance changes with a resolution as fine as 1  $\mu\text{m}$ . When this mode is activated, the current distance to the target is stored as the reference distance, serving as the baseline or

zero-point. Any subsequent change in distance is measured relative to this reference. If the distance to the target increases, the output values will be positive; if the distance decreases, the output values will be negative.

Common Use Cases for High Precision Mode:

### 1. Displacement & Drift Measurements Over Time:

- High Precision Mode can be used to monitor the position of objects over extended periods, such as tracking the temperature drift of equipment.

### 2. Profile Measurement:

- This mode is also ideal for measuring the profile of surfaces by moving the object perpendicular to the radar beam. Unlike laser sensors, High Precision Mode can effectively measure the profile of rough surfaces due to the opening angle and the radar spot size over which the distance is averaged.

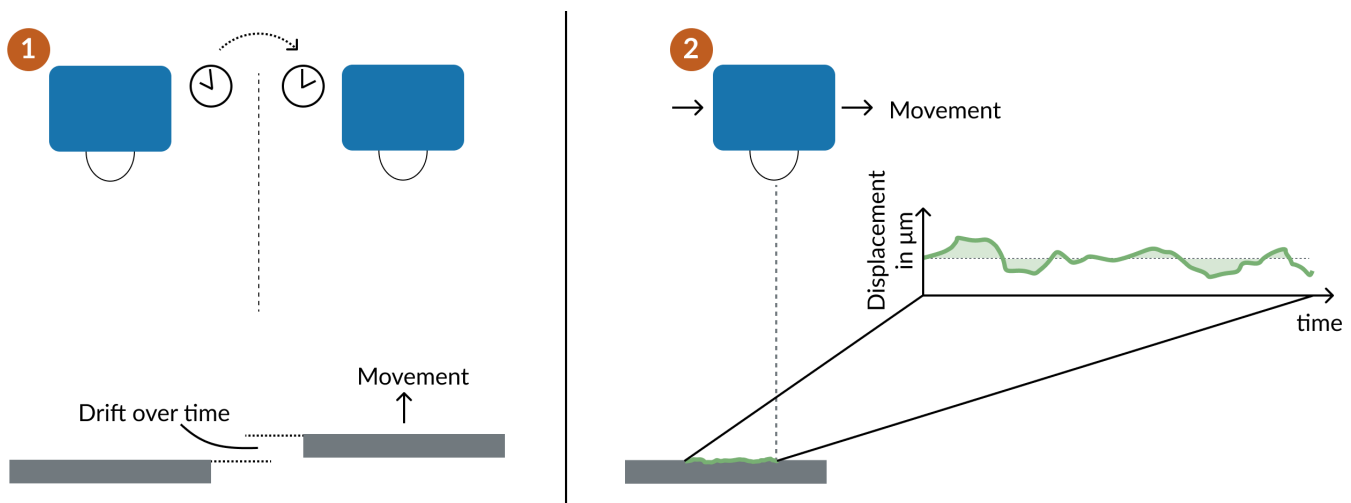

Use cases for high precision mode

## 6.6.1 Setup High Precision Mode

### 1. Initial Configuration with OndoNet:

- Activate the High Precision Mode by clicking on the “Switch Mode” button in the Target View
- Use OndoNet to set your measuring range. Adapt this to your use case to define the smallest possible range.
- Configure the Amplifiers using AutoGain. The IQ data for a fix target should show oscillations without clipping.
- Set the time interval for Reset High Precision Mode after a target loss.
- Select "Maximum Accuracy" as your Profile as it is the first choice for best accuracy. Select “Long range - Slow moving objects” if you have a maximum distance beyond 6 metres.

### 2. Finalize Setup:

- Disconnect your ConfigBox and establish the connection via API.

### 3. Activate High Precision Mode:

- Download the [Application Notes](#)
- Enable High Precision Mode by setting the corresponding result data selector. To stop High Precision Mode, simply set a different result data selector. For detailed instructions, refer to the Application Notes.
- For optimum performance and measurement rate in High Precision Mode, ensure that only High Precision Mode is selected (RESULT\_DATA\_SELECTOR = 512).

### Limitations

- The High Precision Mode is optimized for slow movements. When target movement exceeds **50 mm/s**, target loss events may occur.
- It is possible to combine the absolute distance measurement in the standard mode with the high-precision measurement. This can be useful to first determine the approximate distance to a target before tracking changes of the distance to that target. At the same time, this does not allow for a more accurate absolute distance measurement than via the standard absolute distance measurement. The initial absolute distance measurement will contain an error of a few hundred micrometers, that cannot be eliminated via the displacement measurement with the High Precision Mode.
- The high-precision mode will measure accurate distances for targets whose orientation towards the sensor stays relatively constant. For significant changes of the angle of the target towards the sensor, the accuracy of the high precision mode will be affected.

The **RESET HIGH PRECISION MODE INTERVAL** determines the time after which the measurement in High Precision Mode automatically resets following a target loss. This reset adjusts the baseline value to the current distance. Additionally, you can manually reset the measurement at any time by clicking the “Manual Reset” button.



#### NOTE

The High Precision Mode can not be read out by the current loop or switching outputs. To access the displacement values through the PLC, you need to configure the RS485 connection via the API

## 6.6.2 Target lost handling

When the high-precision mode is set up (i.e. the correct result data selector is chosen), upon receiving a **MEASUREMENT** -command, the sensor returns the high precision distance together with a target lost counter. As long as the sensor is capable of “locking” a given target, the target lost counter keeps the same value. More precisely, the measurement data block corresponding to the high-precision data block consists of 6 bytes: Status (1Byte) + Target Lost Counter (1 byte, unsigned 8-bit integer) + high precision distance in  $\mu\text{m}$  (4 bytes, signed 32-bit integer).

### Reasons for target lost events

There are two scenarios in which a target lost event is identified:



- a) The non-high-precision distance between two consecutive measurements exceeds a certain threshold value defined by the parameter `HIGH_PRECISION_DISTANCE_THRESHOLD` (see section below).
- b) The distance to the target changes by more than ~0.6 mm between two consecutive data points.

The former occurs typically when an obstacle interferes in the measurement path between sensor and target or when the target has a smooth surface and gets tilted away from the sensor, so that the signal path is dominated by paths including clutter reflections.

The latter occurs typically when the target moves too fast away or towards the sensor, see below under limitations.

### Sensor behavior in case of target lost events

Once a target lost event occurs, the sensor increases the target lost counter by one. (Note: If the maximum value of an unsigned 8-bit integer ( 255 ) is reached, the counter resets to zero.) The high-precision data block is now given by a status ( `TARGET_LOST = -7 (0xF9)` ), a target lost counter increased by one and a distance value of zero.

For a parametrizable (see below) amount of time, the sensor will remain in this status before it automatically resumes operation of the high-precision mode. Such a resume resets the high-precision distance to 0. When the measurement resumes, the target lost counter does not increase further and does *not* reset to 0.

### 6.6.3 Manual restart of the high precision mode

When the sensor is setup for high precision mode (i.e. the result data selector includes the corresponding code ( 512 ) ), it is possible to manually reset the high precision mode by sending a `RESTART_HIGH_PRECISION_MOCE (0x19)` command. The sensor will acknowledge the command with an `API_SUCCESS (0x01)` and set the high-precision distance to 0. Note: The command does *not* reset the target lost counter. This command also works if the sensor is in a target-lost waiting timer situation. Once the command is received and processed, the high-precision mode resumes immediately.

## 7 System Management & Maintenance

This chapter focuses on the effective management and upkeep of your sensor system. It includes instructions on saving and loading settings and updating software and firmware.

### 7.1 IP-Adress Configuration

The IP-Adress of LAN port 2 of the ConfigBox can be configured via OndoNet.

This can be helpful to add the ConfigBox to an existing network or to make the measurement data available via OPC UA.

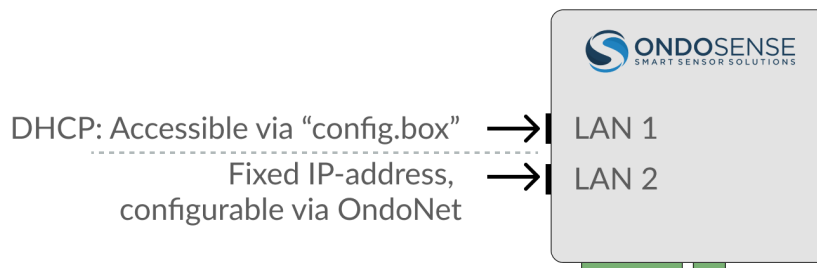

#### To setup a fixed IP address:

- Access OndoNet via LAN1 (config.box).
- Click on **SENSOR MANAGEMENT** in the navigation bar; click on the ⚙️ symbol in the IP Address column.
- In the Pop-up, untick DHCP, enter the desired IP address, Subnet Mask & Default Gateway and Confirm.

Now the new IP address is configured for LAN2. OndoNet and the OPC UA server can now be accessed via the configured IP address.

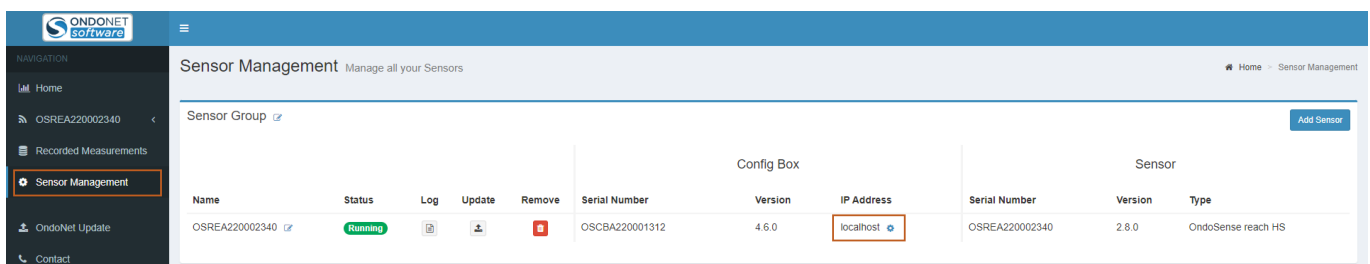

Sensor Management										
Sensor Group										
			Config Box				Sensor			
Name	Status	Log	Update	Remove	Serial Number	Version	IP Address	Serial Number	Version	Type
OSREA220002340	Running				OSGBA220001312	4.6.0	localhost	OSREA220002340	2.8.0	OndoSense reach HS

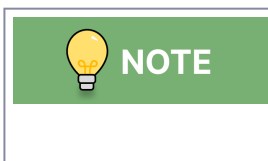

For being able to access the ConfigBox via LAN port 2, the Ethernet port of the PC must be configured with an IP address in the network address space as the IP address that was set. For example if the IP address of the ConfigBox was set to "192.168.10.143", the IP address of the PC needs to be set to "192.168.10.xxx" with xxx being any number except for 143.

## 7.2 Save/Load Configuration



### NOTE

You do not need to save the settings after making adjustments. The sensor automatically retains the configuration changes even if you disconnect it from the ConfigBox and connect it to the PLC. The settings will remain stored on the sensor until you make further changes. Saving the settings is only necessary if you want to create a backup or transfer the configuration to another sensor.

After configuring your sensor to the desired settings, you can save these settings as a file. This saved configuration can then be easily loaded onto another sensor or reloaded onto the same sensor at a later time.

### Save Settings

Once you've configured the sensor, select the Save Settings option. The browser should start downloading a file named "Date\_Time\_Sensor\_Variant\_Settings.os".

---

#### Save Sensor Settings

Save a file containing all sensor settings.

Save

Save Sensor Settings Panel

### Load Settings

To apply a previously saved configuration, use the Load Settings option. Navigate to the location of your saved file and select it. The sensor will then automatically apply the saved settings, replicating the exact configuration on either the same or a different sensor. This process ensures consistency across multiple sensors and saves time when setting up devices for similar tasks.

This functionality is particularly useful when working with multiple sensors in a network, ensuring that all sensors operate with the same optimized settings, or when quickly reapplying configurations after maintenance or sensor replacement.

---

#### Load Sensor Settings

Please select a sensor settings file.

Durchsuchen... Keine Datei ausgewählt.

Load

Load Sensor Settings Panel

### Reset Settings

Resetting the sensor will delete your custom configuration and restore all parameters to their default values. It is recommended to save your current configuration before performing a reset to avoid losing any important settings. This ensures you can easily restore your setup if needed after the reset.

#### Reset Sensor Settings

Custom sensor configuration will be deleted and all configuration parameters will be set back to default values.

Reset

## 7.3 Update Software & Firmware



### NOTE

If you've been instructed or have received an update file from us download the update zip-file via the link provided by email. Unzip the zip-file and update the components in the following order:

### OndoNet Software Update

1. Navigate to OndoNet Update in the user interface
2. Upload the file named "OndoNet... .update".
3. During the update, the connection will be lost. Wait for up to 5 min. and reload the page. Do not unplug the sensor during the update process!

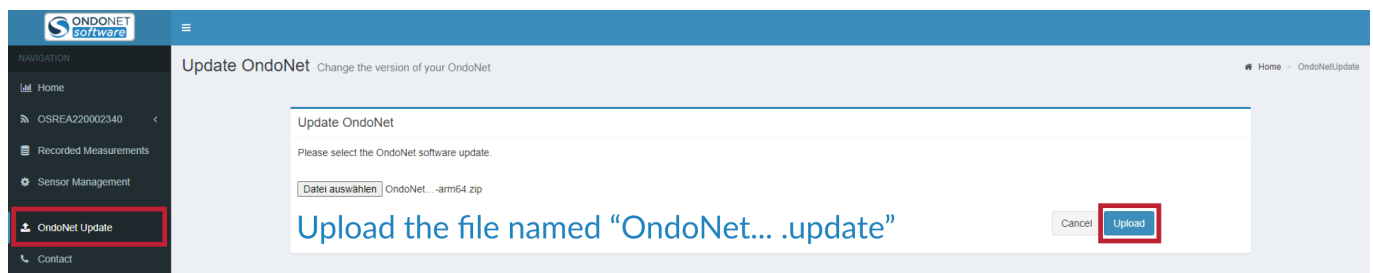

Update OndoNet

### ConfigBox Firmware Update

1. Navigate to OndoNet Update in the user interface and click on the update icon.
2. Upload the file named "OndoSensor... .update".
3. During the update, the connection will be lost. Wait for up to 5 min. and reload the page. Do not unplug the sensor during the update process!

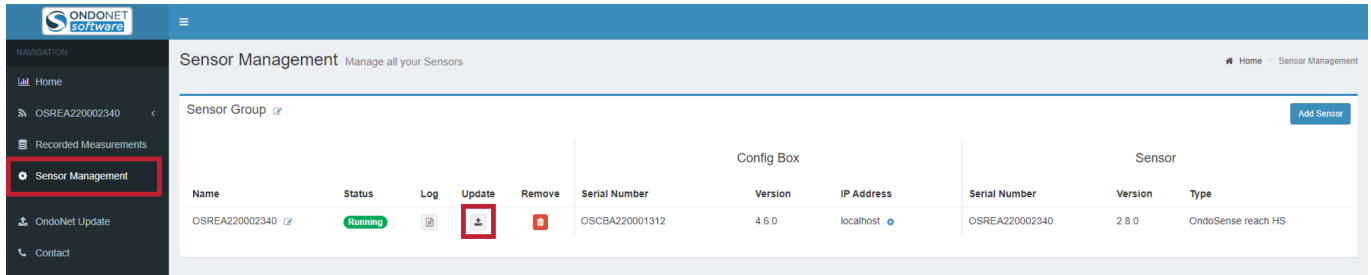

Update ConfigBox und Sensor Firmware

### Sensor Firmware Update

1. Navigate to OndoNet Update in the user interface and click on the update icon (again as in step 2).
2. Upload the file named "Firmware... .update".
3. During the update, the connection will be lost. Wait for up to 5 min. and reload the page. Do not unplug the sensor during the update process!

## 7.4 Maintenance

### NOTICE

#### Do not disassemble the device

Disassembling the device may result in damage, loss of warranty, or malfunction and should only be performed by authorized personnel.

In harsh environments, we recommend regular inspections for firm seating and possible damages at the device. Repair or maintenance work requiring opening the device may only be performed by the manufacturer. In the event of questions or spare parts orders, please provide us the data printed on the type plate of the device.



## 8 Disposal

### NOTICE

#### Proper Disposal Required

Environmental damage in case of incorrect disposal Electrical waste, electronic components, lubricants and other auxiliary materials are subject to hazardous waste treatment. Problem substances may only be disposed of by licensed specialist companies.

Always dispose of unusable or irreparable devices in an environmentally sound manner, according to the country-specific provisions and in compliance with the waste disposal regulations in force. We will be glad to help you dispose of the devices. Please contact us via [support@ondosense.com](mailto:support@ondosense.com)

Dispose of disassembled device components as follows:

- Metal components in the scrap metal.
- Electronic components in the electrical waste.
- Plastic parts in a recycling center.
- Sort and dispose of the other components depending on the material type

## 9 Open Source Licenses

OndoSense is using the following open source projects and licenses:

- gRPC: <https://github.com/grpc/grpc/blob/master/LICENSE>
- protobuf: <https://github.com/protocolbuffers/protobuf/blob/master/LICENSE>
- AdminLTE: <https://github.com/ColorlibHQ/AdminLTE/blob/master/LICENSE>
- flot: <https://github.com/flot/flot/blob/master/LICENSE.txt>
- <http://socket.io> : <https://github.com/socketio/socket.io/blob/master/LICENSE>
- Winston.js: <https://github.com/winstonjs/winston/blob/master/LICENSE>
- Bootstrap: <https://github.com/twbs/bootstrap/blob/master/LICENSE>
- jQuery: <https://github.com/jquery/jquery/blob/master/LICENSE.txt>
- NLog: <https://github.com/NLog/NLog/blob/master/LICENSE.txt>
- Newtonsoft Json: <https://github.com/JamesNK/Newtonsoft.Json/blob/master/LICENSE.md>
- MathNet Numerics: <https://github.com/mathnet/mathnet-numeric/blob/master/LICENSE.md>
- nlohmann: <https://github.com/nlohmann/json/blob/develop/LICENSE.MIT>
- BoschSensortec: [https://github.com/BoschSensortec/BMI160\\_driver/blob/master/LICENSE](https://github.com/BoschSensortec/BMI160_driver/blob/master/LICENSE)

Windows is a trademark of Microsoft Corporation.

Linux is a trademark of Linus Torvalds.

## 10 Contact

### **OndoSense GmbH**

Bötzingen Str. 60

79111 Freiburg im Breisgau

Phone: +49 761 7911 4301

E-Mail: [info@ondosense.com](mailto:info@ondosense.com)

### **Managing Directors:**

Dr.-Ing. Mathias Klenner, Rainer Waltersbacher

### **Support:**

Phone: +49 761 79114765

E-Mail: [support@ondosense.com](mailto:support@ondosense.com)